

ARCHITECTURAL DESIGN PROJECT

CIVIC HOUSING

Location: Tan Thach commune, Chau Thanh town,
Ben Tre province, Vietnam

Junior architect: My-Hung Nguyen
Supervised by: Senior Arch. Vo Ngoc Truong

Year: Nov, 2022 - April 2023
Categories: residential housing

CONTENTS

Intro

1. Site assessment| Brief
2. References
3. Design Concept diagrams

Proposal

/ A

4. Architecture/ Floor plan 1
5. Architecture/ Floor plan 1/ dimension
6. Architecture/ Floor plan 2
7. Architecture/ Floor plan 2/ dimension
8. Architecture/ Roof plan
9. Architecture/ Roof plan/ dimension
10. Architecture/ Elevations
11. Architecture/ Sections
12. Architecture/ Door details
13. Architecture/ 3D visualizations

/ B

14. Interior/ Floor (tiled) plan 1
15. Interior/ Floor (tiled) plan 2
16. Interior/ Ceiling plan 1
17. Interior/ Ceiling plan 2
18. Interior/ Lightning plan 1
19. Interior/ Lightning plan 2
20. Interior/ Outdoor Lightning plan
21. Interior/ Electrical plan 1
22. Interior/ Electrical plan 2
23. Interior/ Outdoor Electrical plan
24. Interior/ Power socket plan 1
25. Interior/ Power socket plan 2

/ C

26. Interior/ Kitchen
27. Interior/ Kitchen/ Furniture
28. Interior/ Living - dining spaces F1
29. Interior/ Common - praying spaces F2
30. Interior/ WC & furniture
31. Interior/ Bedroom & furniture
32. Exterior/ Outdoor spaces
33. Exterior/ Night view

/ D

34. Pattern/ Parametric design

/ E

35. Design process/ Experimentation & Iterations
36. Design process/ Methodology on information management

/ F

37. Remarks

1. SITE ASSESSMENT

Location: Tan Thach commune, Chau Thanh district, Ben Tre province, Vietnam
Area : 50 sqm

North: Tien river
South: Town street width < 3 m
East & West: residential houses

1.1 Site evaluation

Advantage:

North and South sides adjacent to road, and river - opportunity for views

Disadvantage:

Uneven land boundary - difficult for spatial arrangement

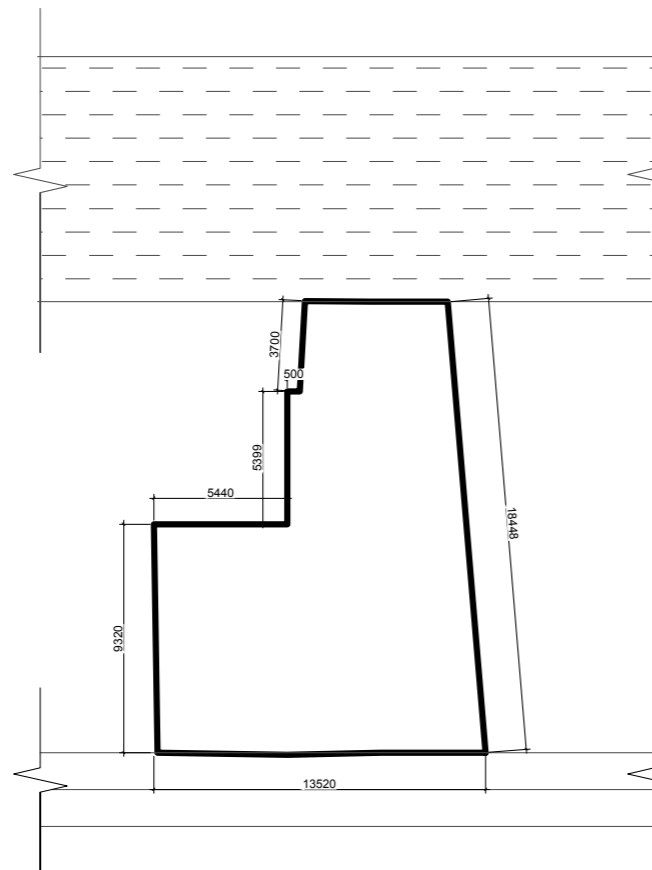

2. BRIEF

- 2 floors
- 4 bedrooms
- 1 living room
- 1 dining room
- 1 common room
- 1 shrining room/ space
- 1 kitchen
- 3 private WC, 1 common WC



3D model for the architectural proposal
 Designer: My-Hung Nguyen

CONTENTS

Intro

1. Site assessment | Brief
2. References
3. Design Concept diagrams

Proposal

/ A

4. Architecture/ Floor plan 1
5. Architecture/ Floor plan 1/ dimension
6. Architecture/ Floor plan 2
7. Architecture/ Floor plan 2/ dimension
8. Architecture/ Roof plan
9. Architecture/ Roof plan/ dimension
10. Architecture/ Elevations
11. Architecture/ Sections
12. Architecture/ Door details
13. Architecture/ 3D visualizations

/ B

14. Interior/ Floor (tiled) plan 1
15. Interior/ Floor (tiled) plan 2
16. Interior/ Ceiling plan 1
17. Interior/ Ceiling plan 2
18. Interior/ Lightning plan 1
19. Interior/ Lightning plan 2
20. Interior/ Outdoor Lightning plan
21. Interior/ Electrical plan 1
22. Interior/ Electrical plan 2
23. Interior/ Outdoor Electrical plan
24. Interior/ Power socket plan 1
25. Interior/ Power socket plan 2

/ C

26. Interior/ Kitchen
27. Interior/ Kitchen/ Furniture
28. Interior/ Living - dining spaces F1
29. Interior/ Common - praying spaces F2
30. Interior/ WC & furniture
31. Interior/ Bedroom & furniture
32. Exterior/ Outdoor spaces
33. Exterior/ Night view

/ D

34. Pattern/ Parametric design

/ E

35. Design process/ Experimentation & Iterations
36. Design process/ Methodology on information management

/ F

37. Remarks

○ Page mark



Neo-classical



Moulding walls



Resting balcony

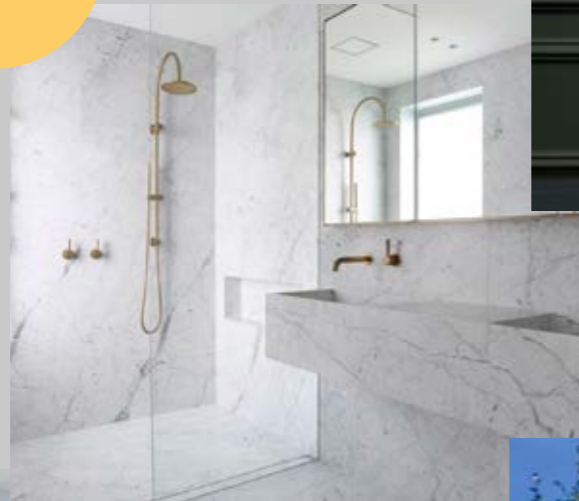

Landmark kitchen & bar



Exterior lightning



Mini-garden



CONTENTS

Intro

- 1. Site assessment | Brief
- 2. References
- 3. Design Concept diagrams

Proposal

/ A

- 4. Architecture/ Floor plan 1
- 5. Architecture/ Floor plan 1/ dimension
- 6. Architecture/ Floor plan 2
- 7. Architecture/ Floor plan 2/ dimension
- 8. Architecture/ Roof plan
- 9. Architecture/ Roof plan/ dimension
- 10. Architecture/ Elevations
- 11. Architecture/ Sections
- 12. Architecture/ Door details
- 13. Architecture/ 3D visualizations

/ B

- 14. Interior/ Floor (tiled) plan 1
- 15. Interior/ Floor (tiled) plan 2
- 16. Interior/ Ceiling plan 1
- 17. Interior/ Ceiling plan 2
- 18. Interior/ Lightning plan 1
- 19. Interior/ Lightning plan 2
- 20. Interior/ Outdoor Lightning plan
- 21. Interior/ Electrical plan 1
- 22. Interior/ Electrical plan 2
- 23. Interior/ Outdoor Electrical plan
- 24. Interior/ Power socket plan 1
- 25. Interior/ Power socket plan 2

/ C

- 26. Interior/ Kitchen
- 27. Interior/ Kitchen/ Furniture
- 28. Interior/ Living - dining spaces F1
- 29. Interior/ Common - praying spaces F2
- 30. Interior/ WC & furniture
- 31. Interior/ Bedroom & furniture
- 32. Exterior/ Outdoor spaces
- 33. Exterior/ Night view

/ D

- 34. Pattern/ Parametric design

/ E

- 35. Design process/ Experimentation & Iterations
- 36. Design process/ Methodology on information management

/ F

- 37. Remarks

○ Page mark

3. CONCEPTUAL ANALYSIS

3.1 Floors and Functional spaces

Roof:
- Skylight
- Gutters

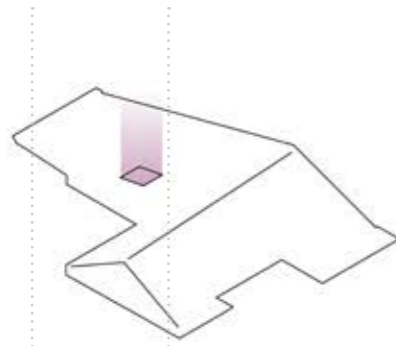

Floor 2 functions:
- Semi-outdoor spaces (balconies)
- Common room x1
- Shrining space x1
- WC x3
- Bedroom x3

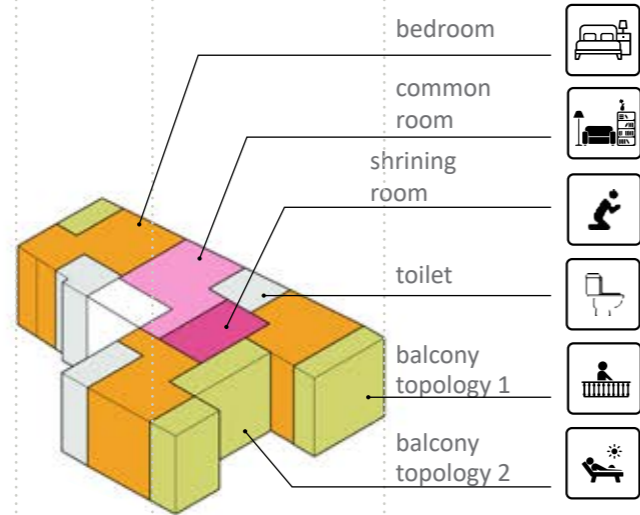

Floor 1 functions:
- Semi-outdoor spaces (mini-garden, balcony, barbecue backyard)
- living room x1
- kitchen x1
- dining room x1
- master bedroom x1
- common WC x1

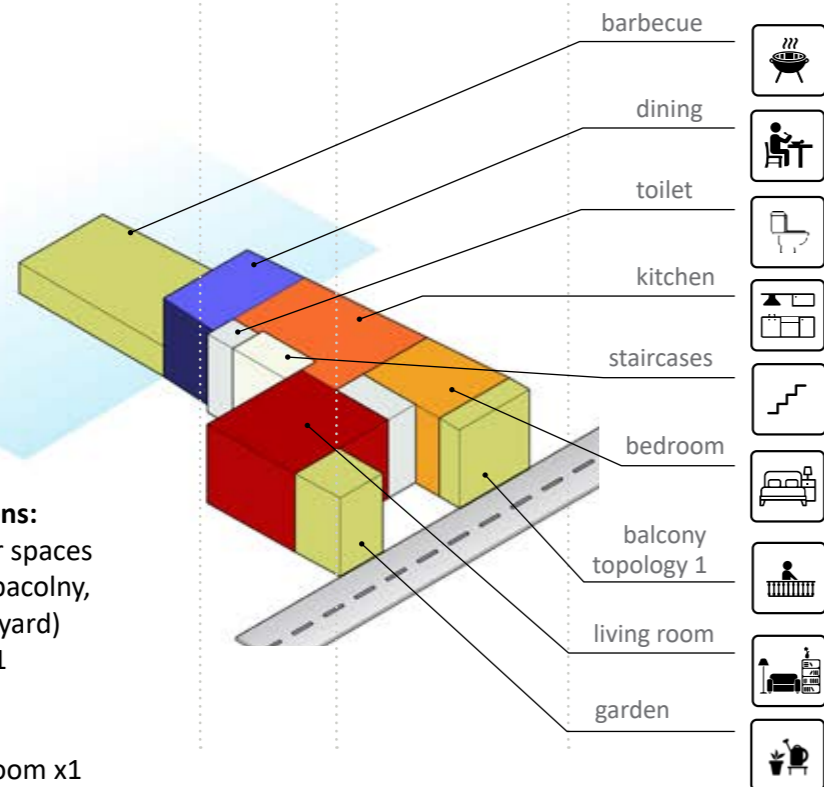

Activities

3.2 Logic in spatial arrangement

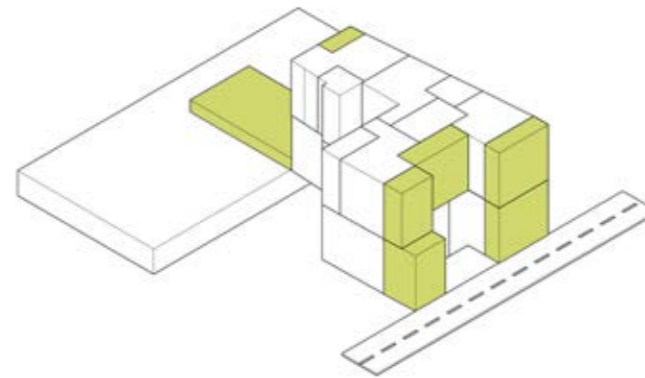

Semi spaces:

- Exploit the site location which is near the riverside and road, to establish series of open and semi-open spaces for outdoor activities, such as: sunbath, barbecue, and views.

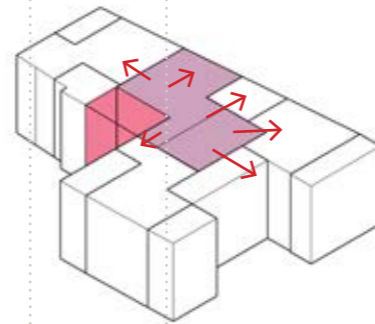

Floor 2 Hallway & common space:

The internal hallway leading to common space, bedrooms, WC praying space and the common balcony.

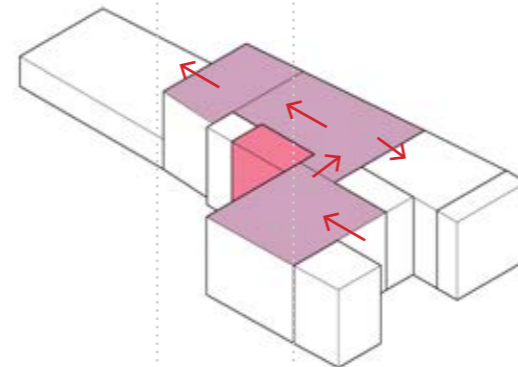

Floor 1 Hallway & common space:

The entrance of the house leads to living room, then kitchen, bar, dining room, common WC, master bedroom, and the backyard for barbecue.

3.3 Creative color tones

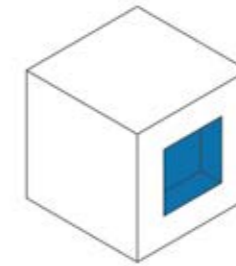

The interplay of 2 tones of colors white and blue proposes the 'inside-out' effect (check Pg.38); especially at night when the interior spaces are lightened up.

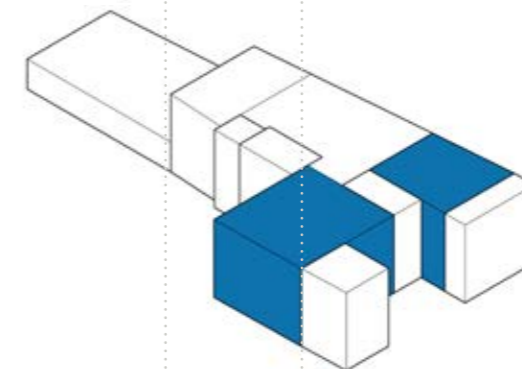

The blue tone is targeted for walls facing towards the street, or the river so that the mixture between exterior tone (white) and interior tone (blue) intrigues attraction.

The inner white tone is transitioned to functional spaces such as: kitchen, dining, common room and hallway, creating a calming effect following the atmosphere triggered by the interior design concept imitating the neo-classical style of architecture.

CONTENTS

Intro

1. Site assessment| Brief
2. References
3. Design Concept diagrams

Proposal

/ A

4. Architecture/ Floor plan 1
5. Architecture/ Floor plan 1/ dimension
6. Architecture/ Floor plan 2
7. Architecture/ Floor plan 2/ dimension
8. Architecture/ Roof plan
9. Architecture/ Roof plan/ dimension
10. Architecture/ Elevations
11. Architecture/ Sections
12. Architecture/ Door details
13. Architecture/ 3D visualizations

/ B

14. Interior/ Floor (tiled) plan 1
15. Interior/ Floor (tiled) plan 2
16. Interior/ Ceiling plan 1
17. Interior/ Ceiling plan 2
18. Interior/ Lightning plan 1
19. Interior/ Lightning plan 2
20. Interior/ Outdoor Lightning plan
21. Interior/ Electrical plan 1
22. Interior/ Electrical plan 2
23. Interior/ Outdoor Electrical plan
24. Interior/ Power socket plan 1
25. Interior/ Power socket plan 2

/ C

26. Interior/ Kitchen
27. Interior/ Kitchen/ Furniture
28. Interior/ Living - dining spaces F1
29. Interior/ Common - praying spaces F2
30. Interior/ WC & furniture
31. Interior/ Bedroom & furniture
32. Exterior/ Outdoor spaces
33. Exterior/ Night view

/ D

34. Pattern/ Parametric design

/ E

35. Design process/ Experimentation & Iterations
36. Design process/ Methodology on information management

/ F

37. Remarks

○ Page mark



SCALE 1/120

FLOOR PLAN 1

CONTENTS

Intro

1. Site assessment | Brief
2. References
3. Design Concept diagrams

Proposal

/ A

4. Architecture/ Floor plan 1
5. Architecture/ Floor plan 1/ dimension
6. Architecture/ Floor plan 2
7. Architecture/ Floor plan 2/ dimension
8. Architecture/ Roof plan
9. Architecture/ Roof plan/ dimension
10. Architecture/ Elevations
11. Architecture/ Sections
12. Architecture/ Door details
13. Architecture/ 3D visualizations

/ B

14. Interior/ Floor (tiled) plan 1
15. Interior/ Floor (tiled) plan 2
16. Interior/ Ceiling plan 1
17. Interior/ Ceiling plan 2
18. Interior/ Lightning plan 1
19. Interior/ Lightning plan 2
20. Interior/ Outdoor Lightning plan
21. Interior/ Electrical plan 1
22. Interior/ Electrical plan 2
23. Interior/ Outdoor Electrical plan
24. Interior/ Power socket plan 1
25. Interior/ Power socket plan 2

/ C

26. Interior/ Kitchen
27. Interior/ Kitchen/ Furniture
28. Interior/ Living - dining spaces F1
29. Interior/ Common - praying spaces F2
30. Interior/ WC & furniture
31. Interior/ Bedroom & furniture
32. Exterior/ Outdoor spaces
33. Exterior/ Night view

/ D

34. Pattern/ Parametric design

/ E

35. Design process/ Experimentation & Iterations
36. Design process/ Methodology on information management

/ F

37. Remarks

4 Page mark

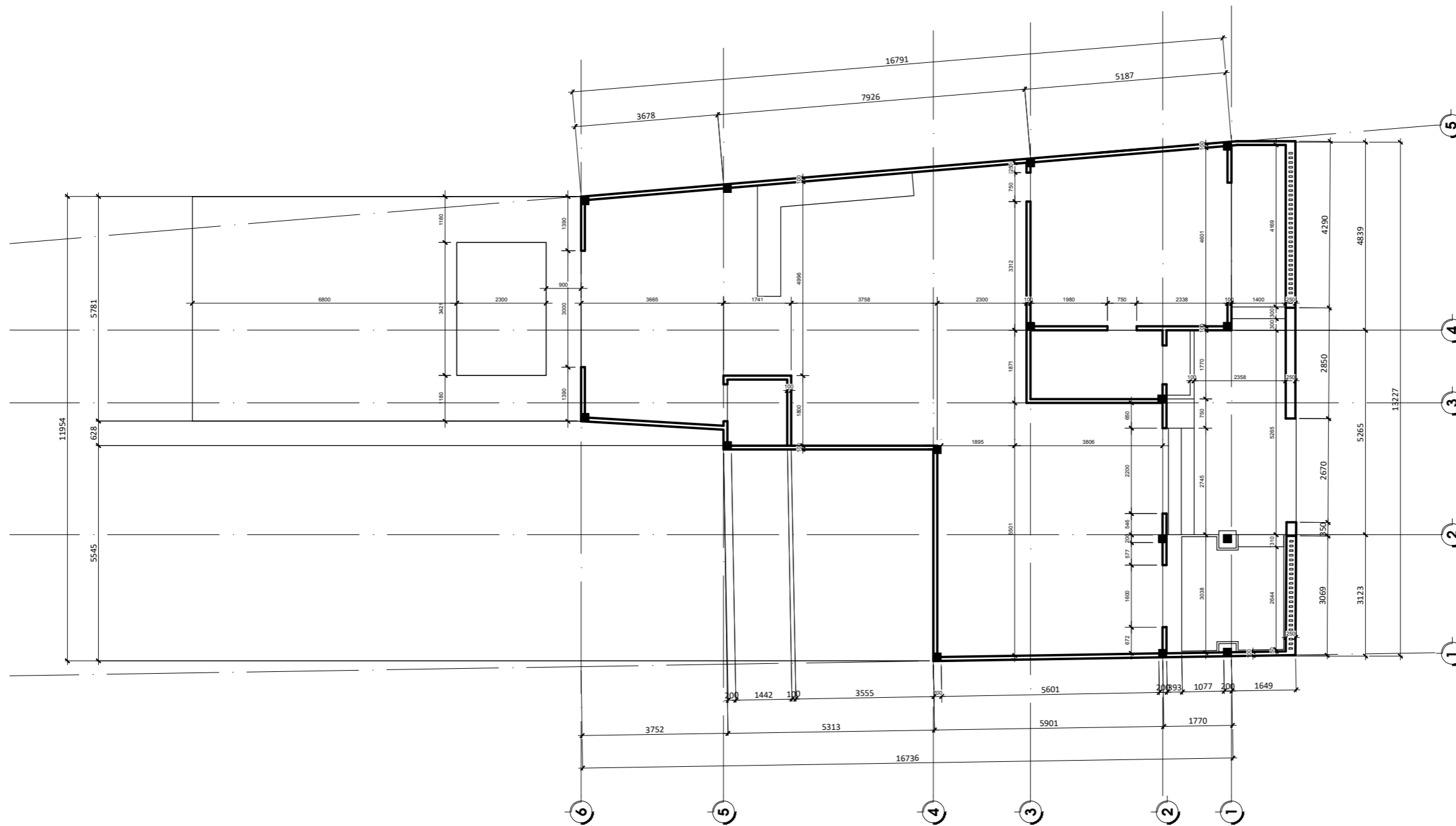

SCALE 1/120

FLOOR PLAN 1/ DIMENSIONS

CONTENTS

Intro

- 1. Site assessment| Brief
- 2. References
- 3. Design Concept diagrams

Proposal

/ A

- 4. Architecture/ Floor plan 1
- 5. Architecture/ Floor plan 1/ dimension
- 6. Architecture/ Floor plan 2
- 7. Architecture/ Floor plan 2/ dimension
- 8. Architecture/ Roof plan
- 9. Architecture/ Roof plan/ dimension
- 10. Architecture/ Elevations
- 11. Architecture/ Sections
- 12. Architecture/ Door details
- 13. Architecture/ 3D visualizations

/ B

- 14. Interior/ Floor (tiled) plan 1
- 15. Interior/ Floor (tiled) plan 2
- 16. Interior/ Ceiling plan 1
- 17. Interior/ Ceiling plan 2
- 18. Interior/ Lightning plan 1
- 19. Interior/ Lightning plan 2
- 20. Interior/ Outdoor Lightning plan
- 21. Interior/ Electrical plan 1
- 22. Interior/ Electrical plan 2
- 23. Interior/ Outdoor Electrical plan
- 24. Interior/ Power socket plan 1
- 25. Interior/ Power socket plan 2

/ C

- 26. Interior/ Kitchen
- 27. Interior/ Kitchen/ Furniture
- 28. Interior/ Living - dining spaces F1
- 29. Interior/ Common - praying spaces F2
- 30. Interior/ WC & furniture
- 31. Interior/ Bedroom & furniture
- 32. Exterior/ Outdoor spaces
- 33. Exterior/ Night view

/ D

- 34. Pattern/ Parametric design

/ E

- 35. Design process/ Experimentation & Iterations
- 36. Design process/ Methodology on information management

/ F

- 37. Remarks

5 Page mark



SCALE 1/120

FLOOR PLAN 2

CONTENTS

Intro

1. Site assessment | Brief
2. References
3. Design Concept diagrams

Proposal

/ A

4. Architecture/ Floor plan 1
5. Architecture/ Floor plan 1/ dimension
6. Architecture/ Floor plan 2
7. Architecture/ Floor plan 2/ dimension
8. Architecture/ Roof plan
9. Architecture/ Roof plan/ dimension
10. Architecture/ Elevations
11. Architecture/ Sections
12. Architecture/ Door details
13. Architecture/ 3D visualizations

/ B

14. Interior/ Floor (tiled) plan 1
15. Interior/ Floor (tiled) plan 2
16. Interior/ Ceiling plan 1
17. Interior/ Ceiling plan 2
18. Interior/ Lightning plan 1
19. Interior/ Lightning plan 2
20. Interior/ Outdoor Lightning plan
21. Interior/ Electrical plan 1
22. Interior/ Electrical plan 2
23. Interior/ Outdoor Electrical plan
24. Interior/ Power socket plan 1
25. Interior/ Power socket plan 2

/ C

26. Interior/ Kitchen
27. Interior/ Kitchen/ Furniture
28. Interior/ Living - dining spaces F1
29. Interior/ Common - praying spaces F2
30. Interior/ WC & furniture
31. Interior/ Bedroom & furniture
32. Exterior/ Outdoor spaces
33. Exterior/ Night view

/ D

34. Pattern/ Parametric design

/ E

35. Design process/ Experimentation & Iterations
36. Design process/ Methodology on information management

/ F

37. Remarks

6 Page mark

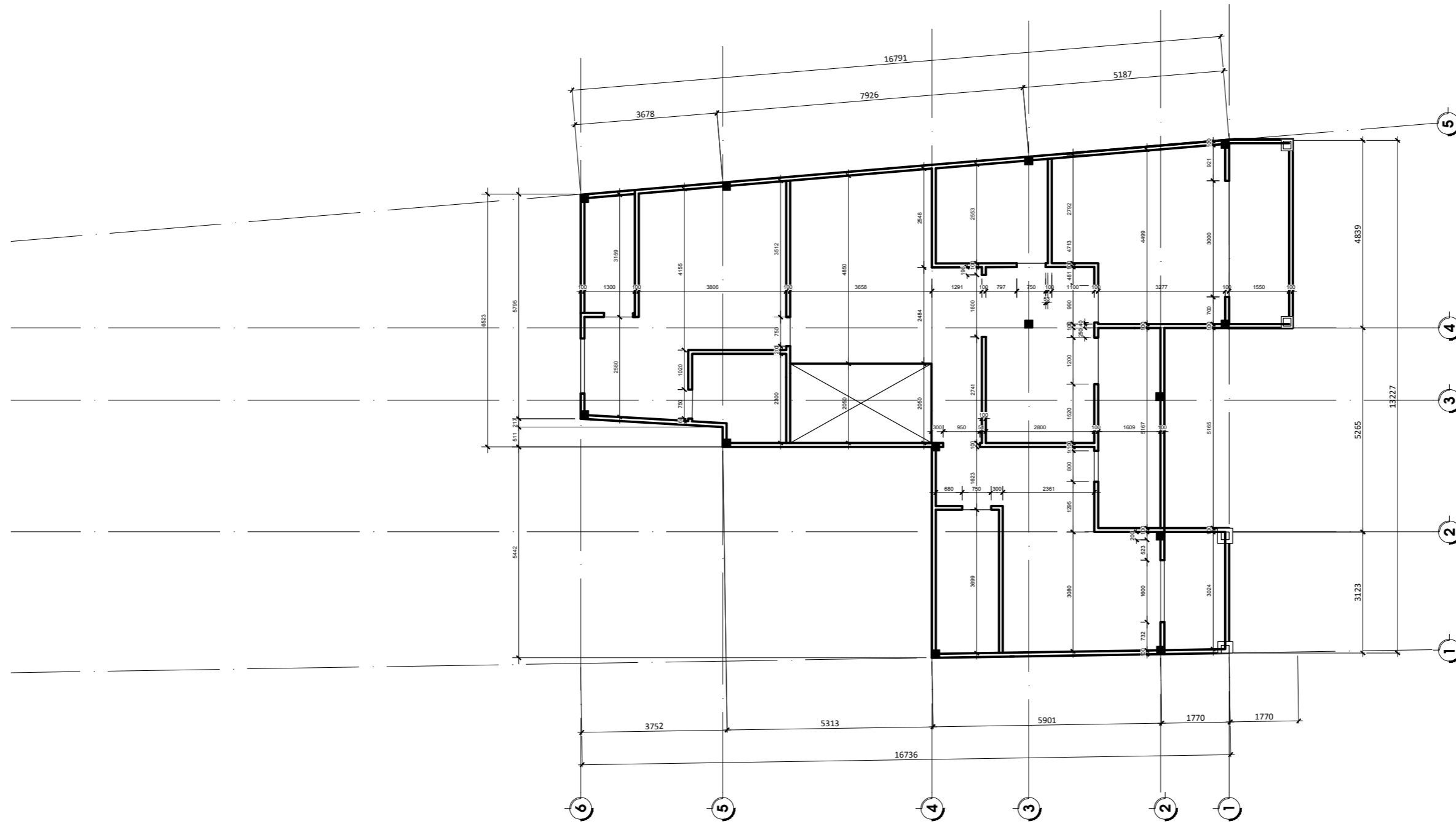

SCALE 1/120

FLOOR PLAN 2/ DIMENSIONS

CONTENTS

Intro

- 1. Site assessment | Brief
- 2. References
- 3. Design Concept diagrams

Proposal

- / A
- 4. Architecture/ Floor plan 1
- 5. Architecture/ Floor plan 1/ dimension
- 6. Architecture/ Floor plan 2
- 7. Architecture/ Floor plan 2/ dimension
- 8. Architecture/ Roof plan
- 9. Architecture/ Roof plan/ dimension
- 10. Architecture/ Elevations
- 11. Architecture/ Sections
- 12. Architecture/ Door details
- 13. Architecture/ 3D visualizations

/ B

- 14. Interior/ Floor (tiled) plan 1
- 15. Interior/ Floor (tiled) plan 2
- 16. Interior/ Ceiling plan 1
- 17. Interior/ Ceiling plan 2
- 18. Interior/ Lightning plan 1
- 19. Interior/ Lightning plan 2
- 20. Interior/ Outdoor Lightning plan
- 21. Interior/ Electrical plan 1
- 22. Interior/ Electrical plan 2
- 23. Interior/ Outdoor Electrical plan
- 24. Interior/ Power socket plan 1
- 25. Interior/ Power socket plan 2

/ C

- 26. Interior/ Kitchen
- 27. Interior/ Kitchen/ Furniture
- 28. Interior/ Living - dining spaces F1
- 29. Interior/ Common - praying spaces F2
- 30. Interior/ WC & furniture
- 31. Interior/ Bedroom & furniture
- 32. Exterior/ Outdoor spaces
- 33. Exterior/ Night view

/ D

- 34. Pattern/ Parametric design

/ E

- 35. Design process/ Experimentation & Iterations
- 36. Design process/ Methodology on information management

/ F

- 37. Remarks

 Page mark

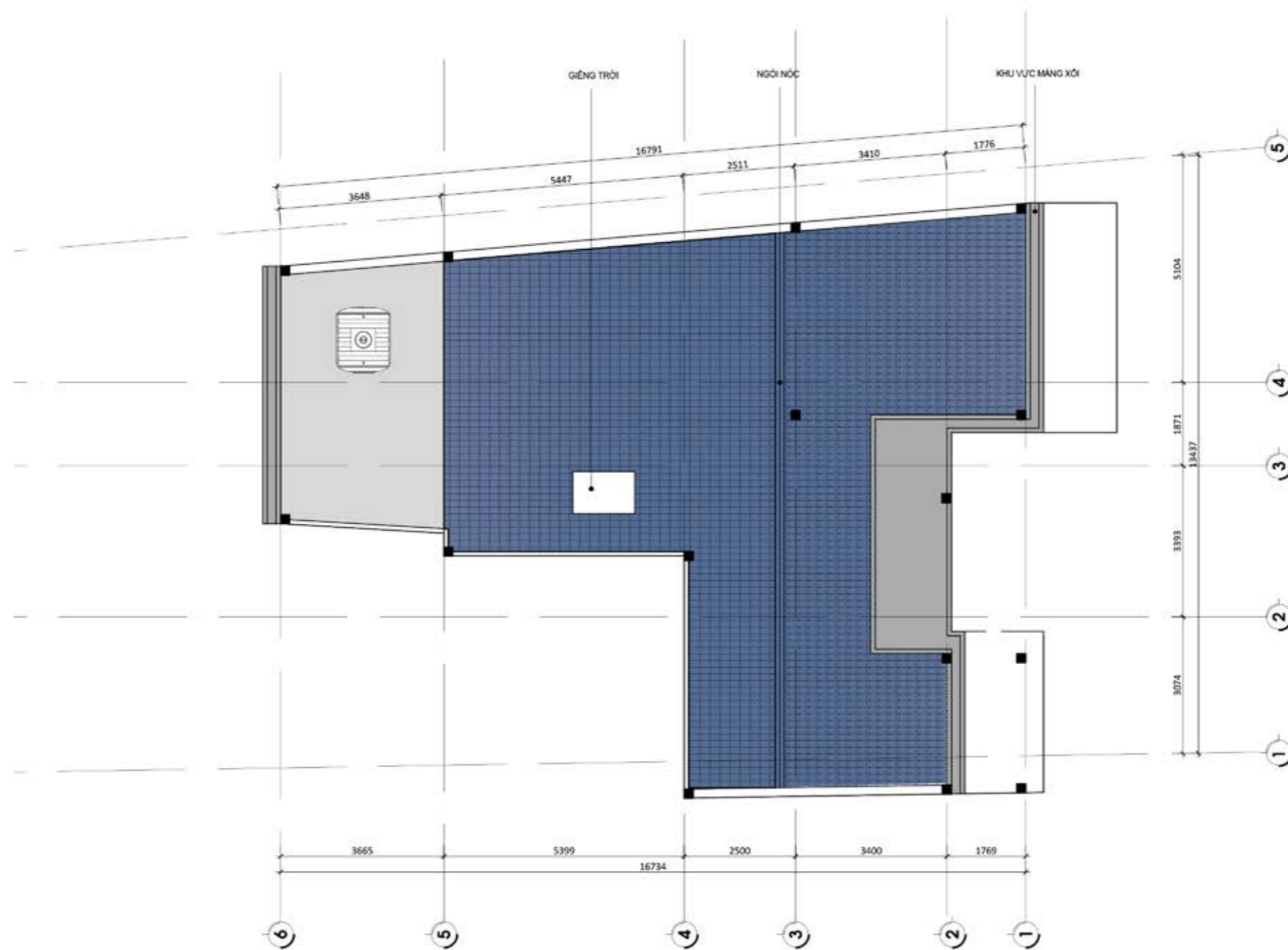

SCALE 1/120

ROOF

CONTENTS

Intro

1. Site assessment| Brief
2. References
3. Design Concept diagrams

Proposal

/ A

4. Architecture/ Floor plan 1
5. Architecture/ Floor plan 1/ dimension
6. Architecture/ Floor plan 2
7. Architecture/ Floor plan 2/ dimension
8. Architecture/ Roof plan
9. Architecture/ Roof plan/ dimension
10. Architecture/ Elevations
11. Architecture/ Sections
12. Architecture/ Door details
13. Architecture/ 3D visualizations

/ B

14. Interior/ Floor (tiled) plan 1
15. Interior/ Floor (tiled) plan 2
16. Interior/ Ceiling plan 1
17. Interior/ Ceiling plan 2
18. Interior/ Lightning plan 1
19. Interior/ Lightning plan 2
20. Interior/ Outdoor Lightning plan
21. Interior/ Electrical plan 1
22. Interior/ Electrical plan 2
23. Interior/ Outdoor Electrical plan
24. Interior/ Power socket plan 1
25. Interior/ Power socket plan 2

/ C

26. Interior/ Kitchen
27. Interior/ Kitchen/ Furniture
28. Interior/ Living - dining spaces F1
29. Interior/ Common - praying spaces F2
30. Interior/ WC & furniture
31. Interior/ Bedroom & furniture
32. Exterior/ Outdoor spaces
33. Exterior/ Night view

/ D

34. Pattern/ Parametric design

/ E

35. Design process/ Experimentation & Iterations
36. Design process/ Methodology on information management

/ F

37. Remarks

8 Page mark

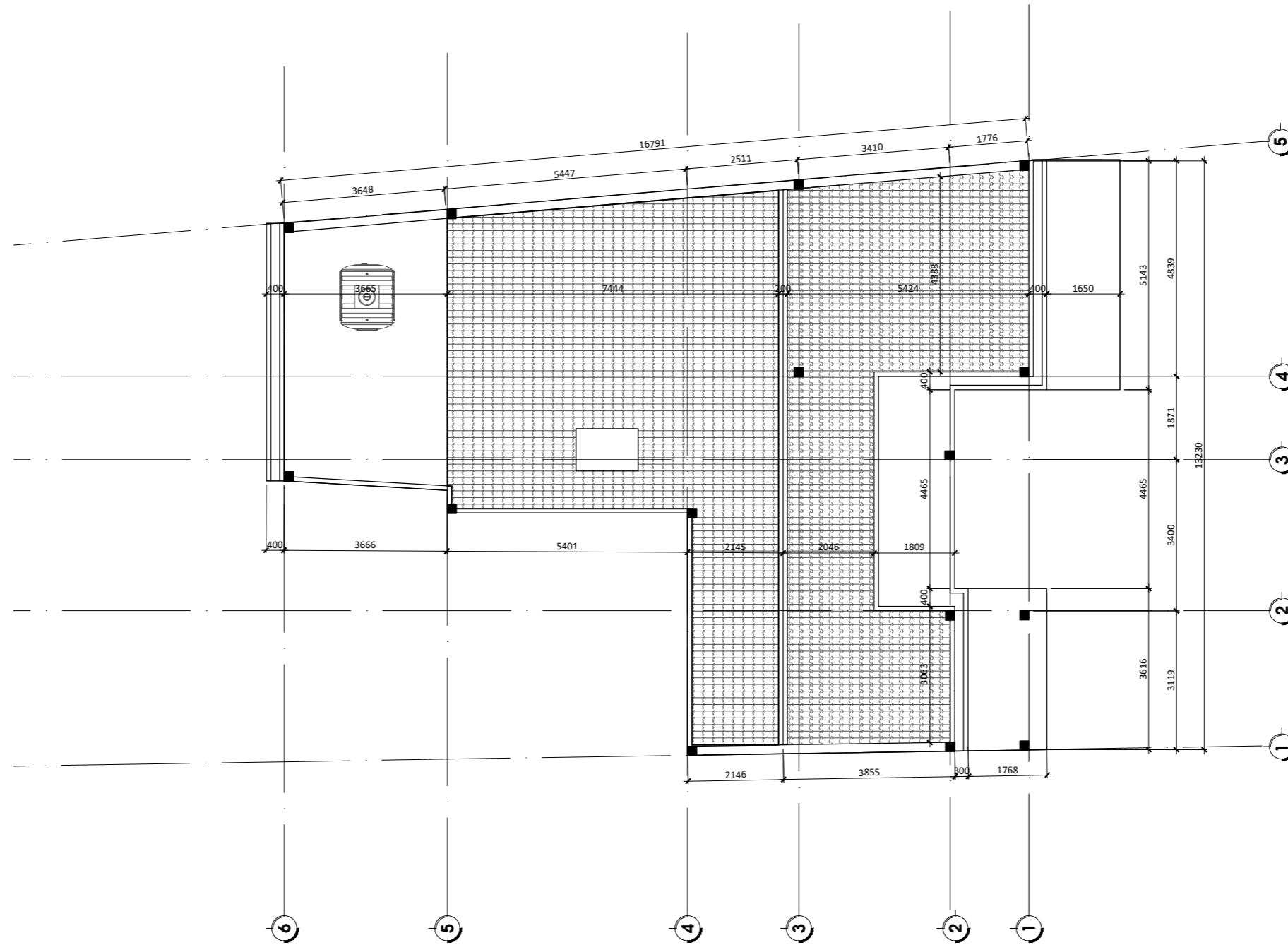

CONTENTS

Intro

1. Site assessment| Brief
2. References
3. Design Concept diagrams

Proposal

/ A

4. Architecture/ Floor plan 1
5. Architecture/ Floor plan 1/ dimension
6. Architecture/ Floor plan 2
7. Architecture/ Floor plan 2/ dimension
8. Architecture/ Roof plan
9. Architecture/ Roof plan/ dimension
10. Architecture/ Elevations
11. Architecture/ Sections
12. Architecture/ Door details
13. Architecture/ 3D visualizations

/ B

14. Interior/ Floor (tiled) plan 1
15. Interior/ Floor (tiled) plan 2
16. Interior/ Ceiling plan 1
17. Interior/ Ceiling plan 2
18. Interior/ Lightning plan 1
19. Interior/ Lightning plan 2
20. Interior/ Outdoor Lightning plan
21. Interior/ Electrical plan 1
22. Interior/ Electrical plan 2
23. Interior/ Outdoor Electrical plan
24. Interior/ Power socket plan 1
25. Interior/ Power socket plan 2

/ C

26. Interior/ Kitchen
27. Interior/ Kitchen/ Furniture
28. Interior/ Living - dining spaces F1
29. Interior/ Common - praying spaces F2
30. Interior/ WC & furniture
31. Interior/ Bedroom & furniture
32. Exterior/ Outdoor spaces
33. Exterior/ Night view

/ D

34. Pattern/ Parametric design

/ E

35. Design process/ Experimentation & Iterations
36. Design process/ Methodology on information management

/ F

37. Remarks

9 Page mark



SCALE 1/120

ROOF/ DIMENSIONS



SCALE 1/120
ELEVATION-FRONT (WITHOUT GATE)

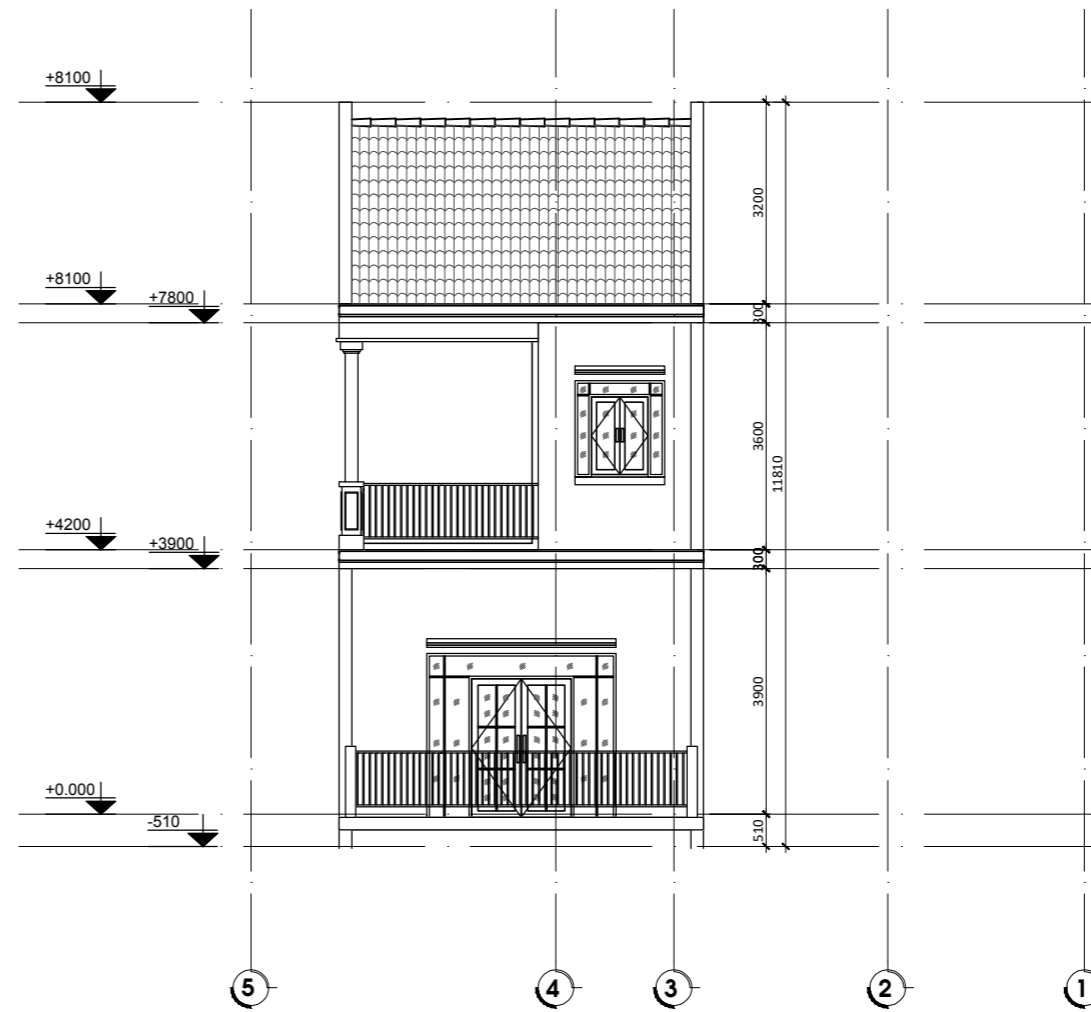

SCALE 1/120
ELEVATION-BACK

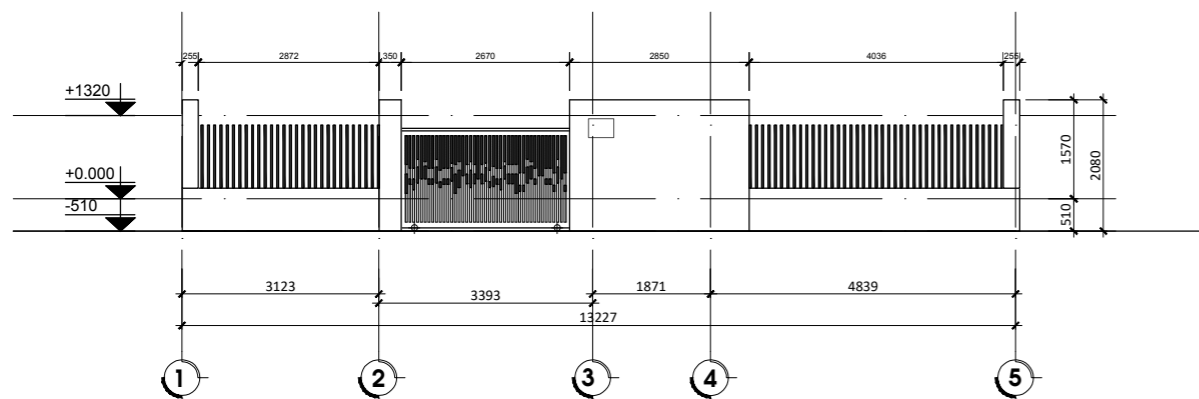

SCALE 1/120
ELEVATION GATE

CONTENTS

Intro

1. Site assessment| Brief
2. References
3. Design Concept diagrams

Proposal

/ A

4. Architecture/ Floor plan 1
5. Architecture/ Floor plan 1/ dimension
6. Architecture/ Floor plan 2
7. Architecture/ Floor plan 2/ dimension
8. Architecture/ Roof plan
9. Architecture/ Roof plan/ dimension
10. Architecture/ Elevations
11. Architecture/ Sections
12. Architecture/ Door details
13. Architecture/ 3D visualizations

/ B

14. Interior/ Floor (tiled) plan 1
15. Interior/ Floor (tiled) plan 2
16. Interior/ Ceiling plan 1
17. Interior/ Ceiling plan 2
18. Interior/ Lightning plan 1
19. Interior/ Lightning plan 2
20. Interior/ Outdoor Lightning plan
21. Interior/ Electrical plan 1
22. Interior/ Electrical plan 2
23. Interior/ Outdoor Electrical plan
24. Interior/ Power socket plan 1
25. Interior/ Power socket plan 2

/ C

26. Interior/ Kitchen
27. Interior/ Kitchen/ Furniture
28. Interior/ Living - dining spaces F1
29. Interior/ Common - praying spaces F2
30. Interior/ WC & furniture
31. Interior/ Bedroom & furniture
32. Exterior/ Outdoor spaces
33. Exterior/ Night view

/ D

34. Pattern/ Parametric design

/ E

35. Design process/ Experimentation & Iterations
36. Design process/ Methodology on information management

/ F

37. Remarks

10 Page mark

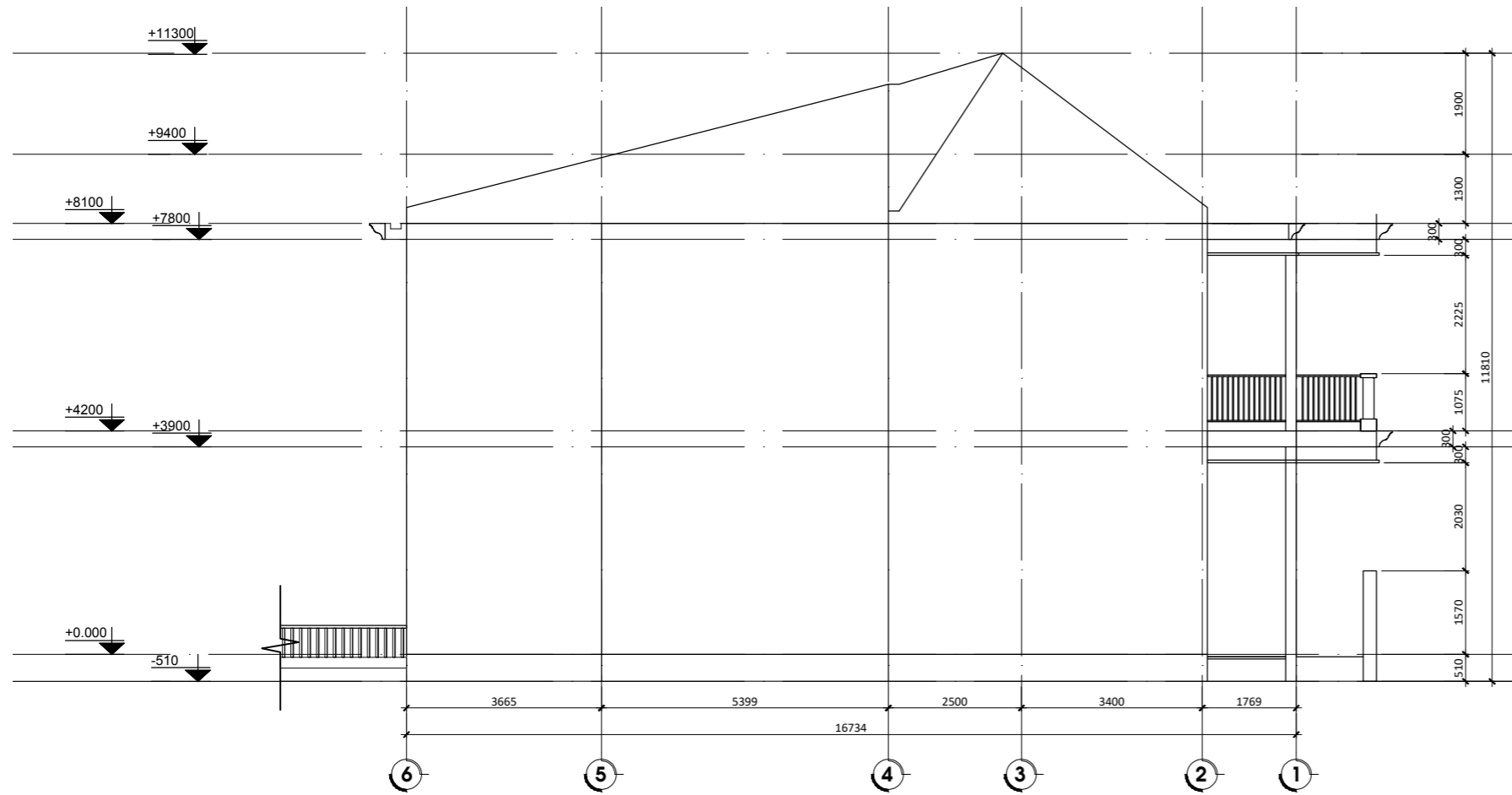

SCALE 1/120
ELEVATION SIDE 6-1

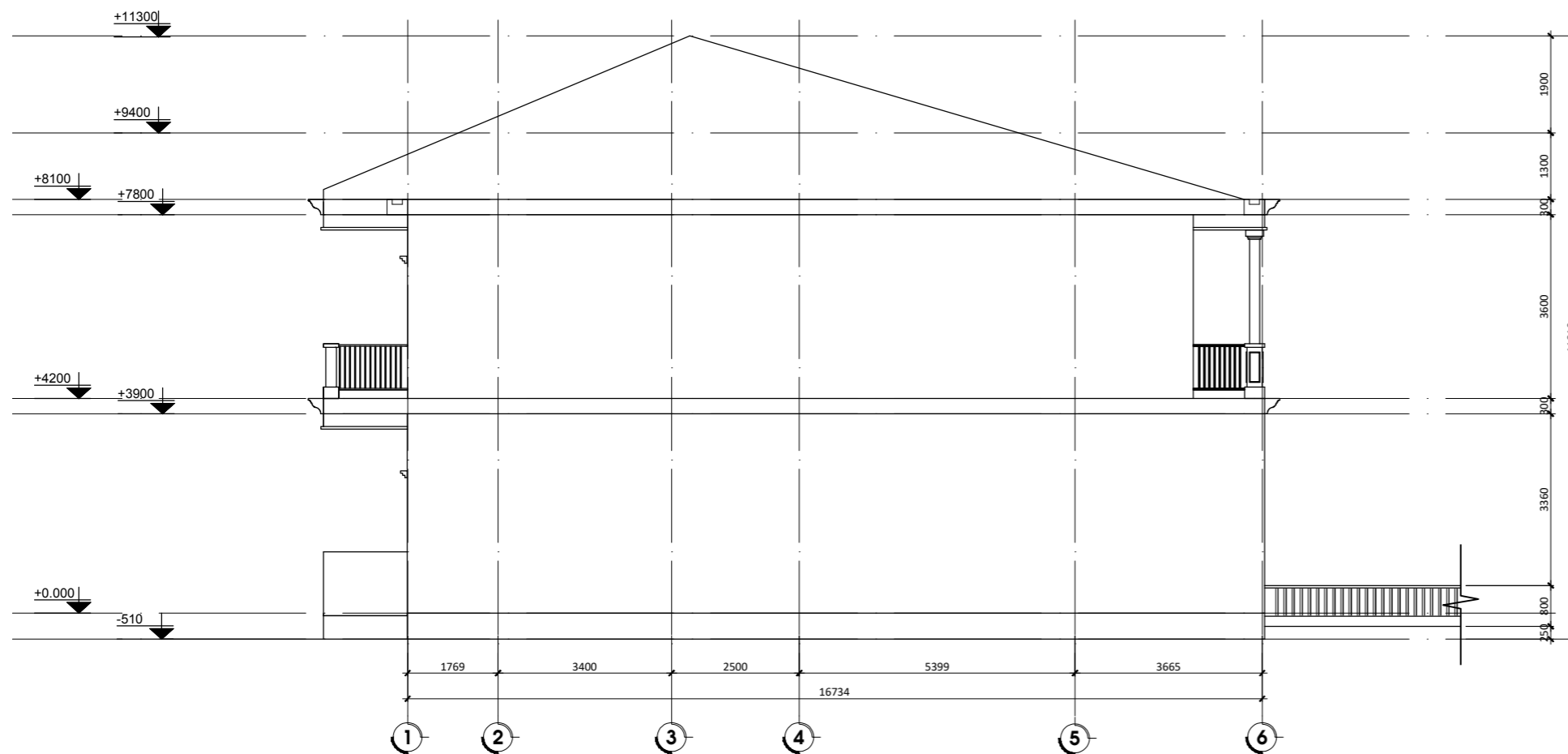

SCALE 1/120
ELEVATION SIDE 1-6

CONTENTS

Intro

1. Site assessment| Brief
2. References
3. Design Concept diagrams

Proposal

/ A

4. Architecture/ Floor plan 1
5. Architecture/ Floor plan 1/ dimension
6. Architecture/ Floor plan 2
7. Architecture/ Floor plan 2/ dimension
8. Architecture/ Roof plan
9. Architecture/ Roof plan/ dimension

10. Architecture/ Elevations

11. Architecture/ Sections
12. Architecture/ Door details
13. Architecture/ 3D visualizations

/ B

14. Interior/ Floor (tiled) plan 1
15. Interior/ Floor (tiled) plan 2
16. Interior/ Ceiling plan 1
17. Interior/ Ceiling plan 2
18. Interior/ Lightning plan 1
19. Interior/ Lightning plan 2
20. Interior/ Outdoor Lightning plan
21. Interior/ Electrical plan 1
22. Interior/ Electrical plan 2
23. Interior/ Outdoor Electrical plan
24. Interior/ Power socket plan 1
25. Interior/ Power socket plan 2

/ C

26. Interior/ Kitchen
27. Interior/ Kitchen/ Furniture
28. Interior/ Living - dining spaces F1
29. Interior/ Common - praying spaces F2
30. Interior/ WC & furniture
31. Interior/ Bedroom & furniture
32. Exterior/ Outdoor spaces
33. Exterior/ Night view

/ D

34. Pattern/ Parametric design

/ E

35. Design process/ Experimentation & Iterations
36. Design process/ Methodology on information management

/ F

37. Remarks

Page mark



SCALE 1/120
SECTION 1-6

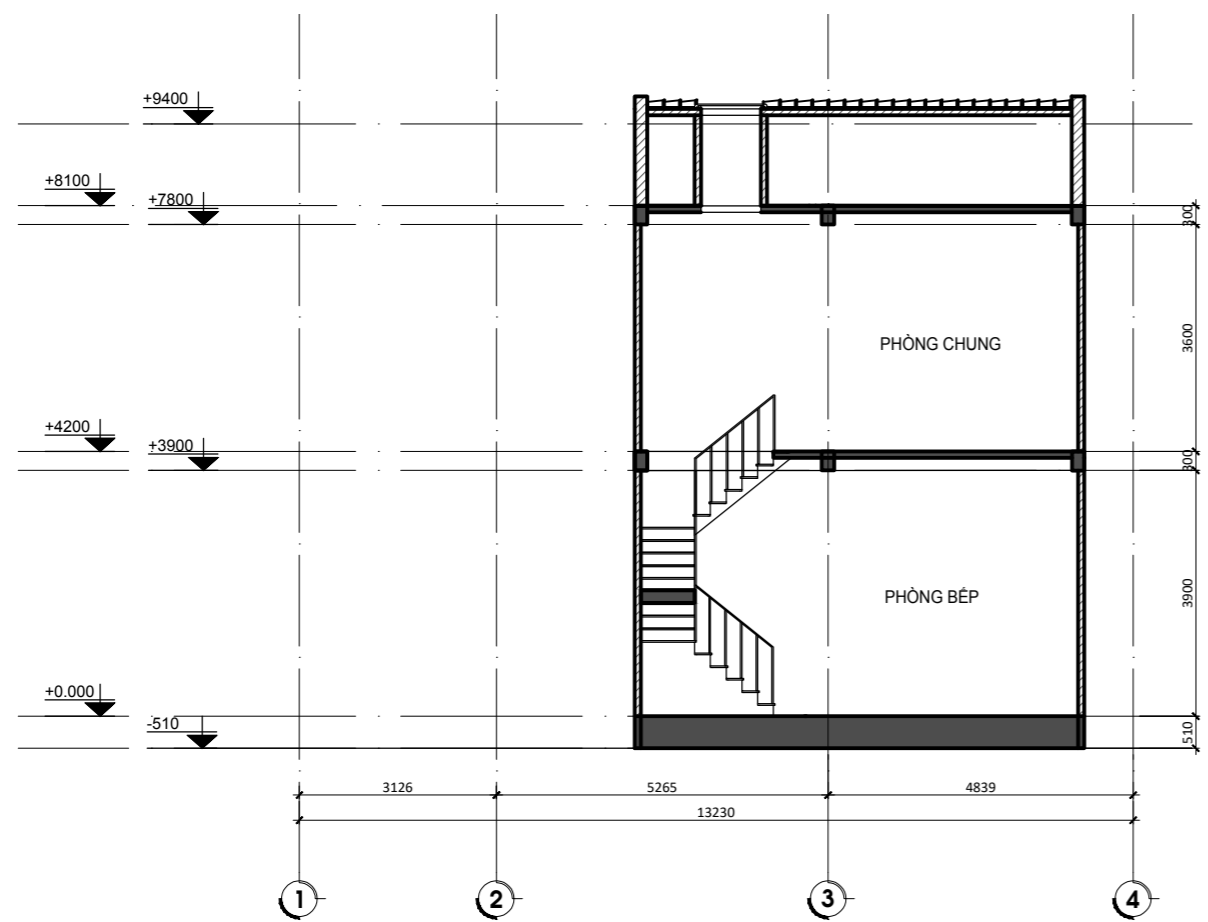

SCALE 1/120
SECTION 1-4

CONTENTS

Intro

1. Site assessment | Brief
2. References
3. Design Concept diagrams

Proposal

/ A

4. Architecture/ Floor plan 1
5. Architecture/ Floor plan 1/ dimension
6. Architecture/ Floor plan 2
7. Architecture/ Floor plan 2/ dimension
8. Architecture/ Roof plan
9. Architecture/ Roof plan/ dimension
10. Architecture/ Elevations
11. Architecture/ Sections
12. Architecture/ Door details
13. Architecture/ 3D visualizations

/ B

14. Interior/ Floor (tiled) plan 1
15. Interior/ Floor (tiled) plan 2
16. Interior/ Ceiling plan 1
17. Interior/ Ceiling plan 2
18. Interior/ Lightning plan 1
19. Interior/ Lightning plan 2
20. Interior/ Outdoor Lightning plan
21. Interior/ Electrical plan 1
22. Interior/ Electrical plan 2
23. Interior/ Outdoor Electrical plan
24. Interior/ Power socket plan 1
25. Interior/ Power socket plan 2

/ C

26. Interior/ Kitchen
27. Interior/ Kitchen/ Furniture
28. Interior/ Living - dining spaces F1
29. Interior/ Common - praying spaces F2
30. Interior/ WC & furniture
31. Interior/ Bedroom & furniture
32. Exterior/ Outdoor spaces
33. Exterior/ Night view

/ D

34. Pattern/ Parametric design

/ E

35. Design process/ Experimentation & Iterations
36. Design process/ Methodology on information management

/ F

37. Remarks

○ Page mark

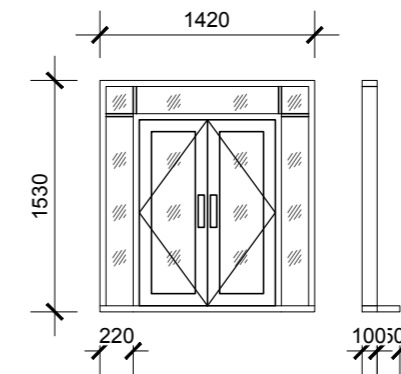
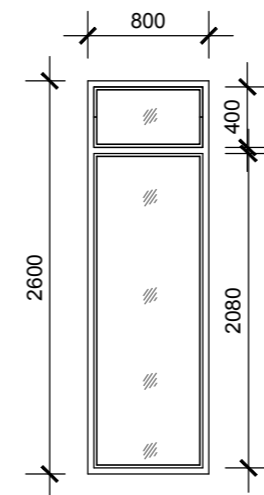
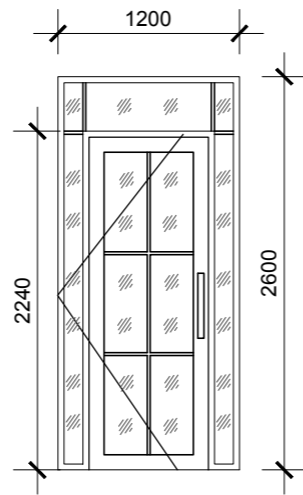
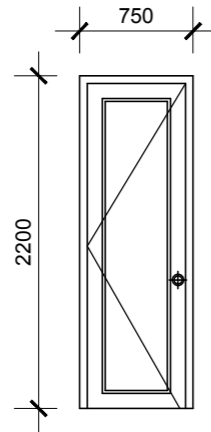
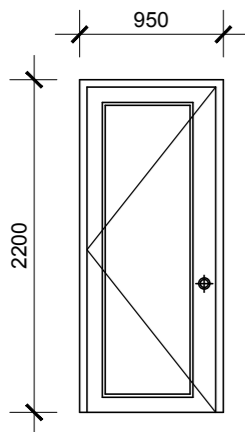
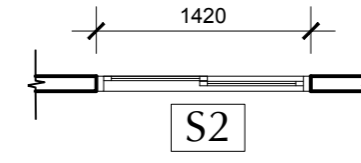
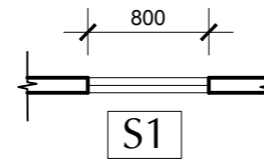
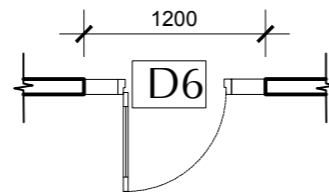
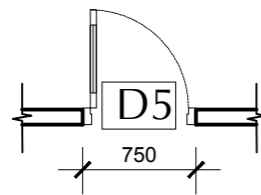
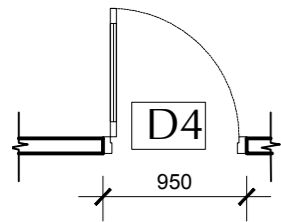
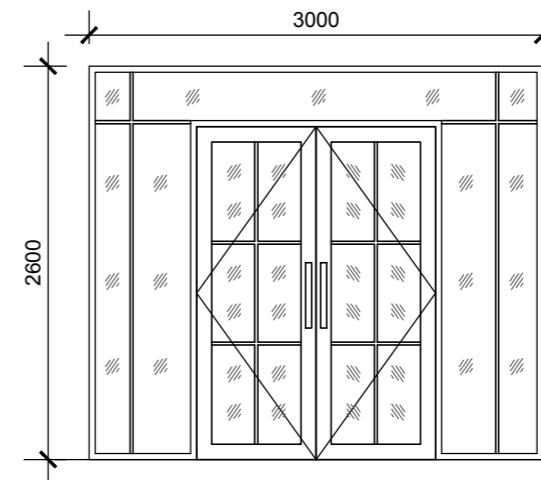
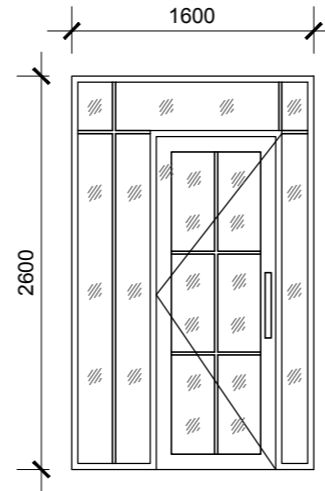
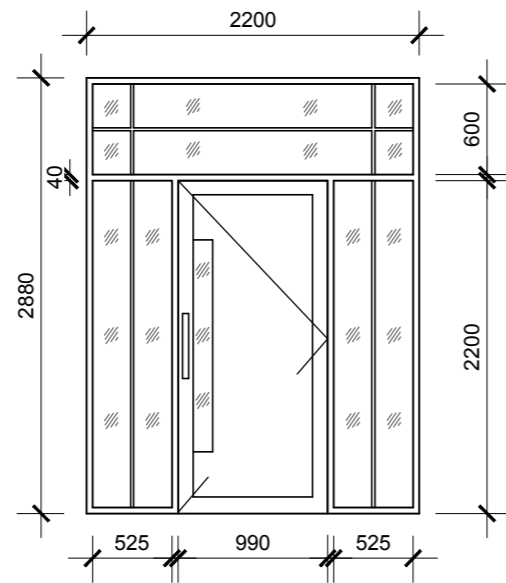
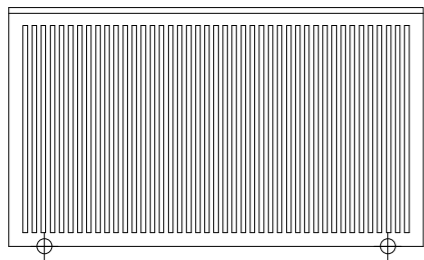
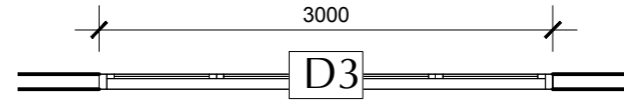
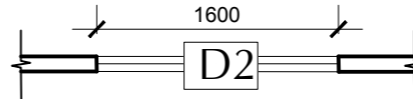
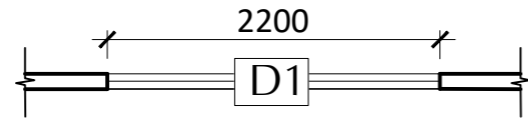
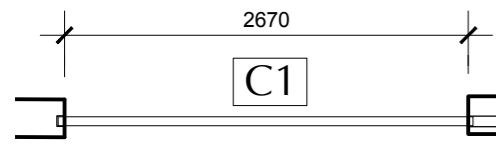

SCALE 1/50

DETAIL/ DOORS & WINDOWS

CONTENTS

Intro

1. Site assessment| Brief
2. References
3. Design Concept diagrams

Proposal

/ A

4. Architecture/ Floor plan 1
5. Architecture/ Floor plan 1/ dimension
6. Architecture/ Floor plan 2
7. Architecture/ Floor plan 2/ dimension
8. Architecture/ Roof plan
9. Architecture/ Roof plan/ dimension
10. Architecture/ Elevations
11. Architecture/ Sections
12. Architecture/ Door details
13. Architecture/ 3D visualizations

/ B

14. Interior/ Floor (tiled) plan 1
15. Interior/ Floor (tiled) plan 2
16. Interior/ Ceiling plan 1
17. Interior/ Ceiling plan 2
18. Interior/ Lightning plan 1
19. Interior/ Lightning plan 2
20. Interior/ Outdoor Lightning plan
21. Interior/ Electrical plan 1
22. Interior/ Electrical plan 2
23. Interior/ Outdoor Electrical plan
24. Interior/ Power socket plan 1
25. Interior/ Power socket plan 2

/ C

26. Interior/ Kitchen
27. Interior/ Kitchen/ Furniture
28. Interior/ Living - dining spaces F1
29. Interior/ Common - praying spaces F2
30. Interior/ WC & furniture
31. Interior/ Bedroom & furniture
32. Exterior/ Outdoor spaces
33. Exterior/ Night view

/ D

34. Pattern/ Parametric design

/ E

35. Design process/ Experimentation & Iterations
36. Design process/ Methodology on information management

/ F

37. Remarks

Page mark



CONTENTS

Intro

1. Site assessment | Brief
2. References
3. Design Concept diagrams

Proposal

/ A

4. Architecture/ Floor plan 1
5. Architecture/ Floor plan 1/ dimension
6. Architecture/ Floor plan 2
7. Architecture/ Floor plan 2/ dimension
8. Architecture/ Roof plan
9. Architecture/ Roof plan/ dimension
10. Architecture/ Elevations
11. Architecture/ Sections
12. Architecture/ Door details
13. Architecture/ 3D visualizations

/ B

14. Interior/ Floor (tiled) plan 1
15. Interior/ Floor (tiled) plan 2
16. Interior/ Ceiling plan 1
17. Interior/ Ceiling plan 2
18. Interior/ Lightning plan 1
19. Interior/ Lightning plan 2
20. Interior/ Outdoor Lightning plan
21. Interior/ Electrical plan 1
22. Interior/ Electrical plan 2
23. Interior/ Outdoor Electrical plan
24. Interior/ Power socket plan 1
25. Interior/ Power socket plan 2

/ C

26. Interior/ Kitchen
27. Interior/ Kitchen/ Furniture
28. Interior/ Living - dining spaces F1
29. Interior/ Common - praying spaces F2
30. Interior/ WC & furniture
31. Interior/ Bedroom & furniture
32. Exterior/ Outdoor spaces
33. Exterior/ Night view

/ D

34. Pattern/ Parametric design

/ E

35. Design process/ Experimentation & Iterations
36. Design process/ Methodology on information management

/ F

37. Remarks

○ Page mark

CONTENTS

Intro

1. Site assessment| Brief
2. References
3. Design Concept diagrams

Proposal

/ A

4. Architecture/ Floor plan 1
5. Architecture/ Floor plan 1/ dimension
6. Architecture/ Floor plan 2
7. Architecture/ Floor plan 2/ dimension
8. Architecture/ Roof plan
9. Architecture/ Roof plan/ dimension
10. Architecture/ Elevations
11. Architecture/ Sections
12. Architecture/ Door details
13. Architecture/ 3D visualizations

/ B

14. Interior/ Floor (tiled) plan 1
15. Interior/ Floor (tiled) plan 2
16. Interior/ Ceiling plan 1
17. Interior/ Ceiling plan 2
18. Interior/ Lightning plan 1
19. Interior/ Lightning plan 2
20. Interior/ Outdoor Lightning plan
21. Interior/ Electrical plan 1
22. Interior/ Electrical plan 2
23. Interior/ Outdoor Electrical plan
24. Interior/ Power socket plan 1
25. Interior/ Power socket plan 2

/ C

26. Interior/ Kitchen
27. Interior/ Kitchen/ Furniture
28. Interior/ Living - dining spaces F1
29. Interior/ Common - praying spaces F2
30. Interior/ WC & furniture
31. Interior/ Bedroom & furniture
32. Exterior/ Outdoor spaces
33. Exterior/ Night view

/ D

34. Pattern/ Parametric design

/ E

35. Design process/ Experimentation & Iterations
36. Design process/ Methodology on information management

/ F

37. Remarks

14 Page mark

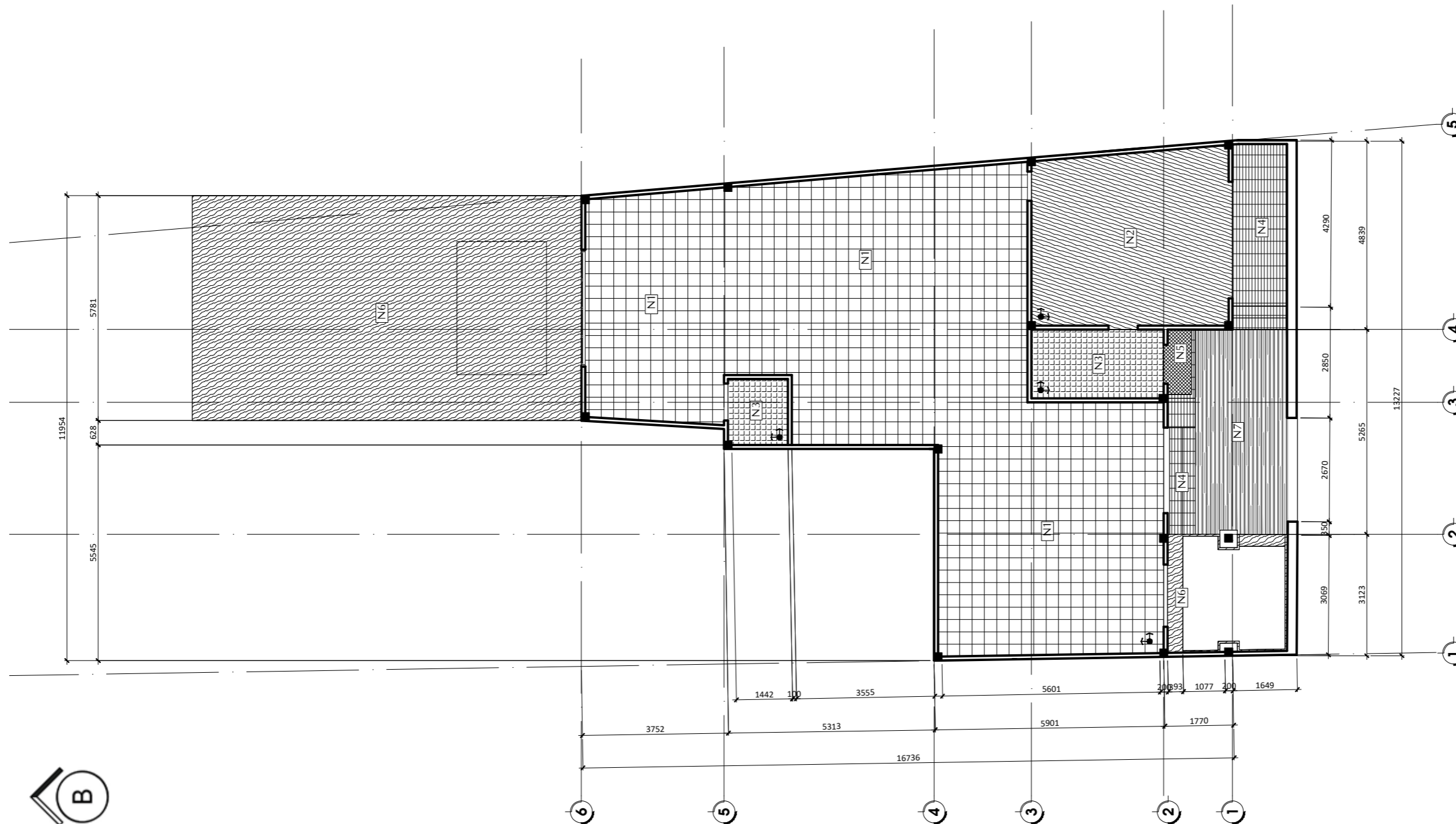

SCALE 1/120

FLOOR (TILED) PLAN 1

<p>N1</p> <ul style="list-style-type: none"> - LÁT GẠCH GRANITE KT 800X800 MÀU GIA CHỦ LỰA CHỌN - LỚP VỮA LÁT NỀN DÀY 30/75 - LỚP BÊ TÔNG ĐÁ (10X20), DÀY 100 - LỚP ĐÁT ĐÁP NỀN ĐÀM CHẶT - LỚP ĐÁT TỰ NHIÊN DỌN SẠCH 	<p>N2</p> <ul style="list-style-type: none"> - LÁT GỖ THANH 145X1200X8 - LỚP VỮA LÁT NỀN DÀY 30/75 - LỚP BÊ TÔNG ĐÁ (10X20), DÀY 100 - LỚP ĐÁT ĐÁP NỀN ĐÀM CHẶT - LỚP ĐÁT TỰ NHIÊN DỌN SẠCH 	<p>N3</p> <ul style="list-style-type: none"> - LÁT GẠCH CERAMIC KT 300X300 MÀU GIA CHỦ TỰ CHỌN, CHỐNG TRƯỢT - LỚP VỮA LÁT NỀN DÀY 30/75, TẠO ĐỐC I=2% VỀ LỖ THU NƯỚC - LỚP ĐÁT ĐÁP NỀN ĐÀM CHẶT - LỚP ĐÁT TỰ NHIÊN DỌN SẠCH 	<p>N4</p> <ul style="list-style-type: none"> - LÁT GẠCH GRANITE KT 800X800 MÀU GIA CHỦ LỰA CHỌN - LỚP VỮA LÁT NỀN DÀY 30/75 - LỚP BÊ TÔNG ĐÁ (10X20), DÀY 100 - LỚP ĐÁT ĐÁP NỀN ĐÀM CHẶT - LỚP ĐÁT TỰ NHIÊN DỌN SẠCH 	<p>N5</p> <ul style="list-style-type: none"> - LÁT GẠCH MOSAIC CERAMIC KT 40X40 MÀU GIA CHỦ TỰ CHỌN, CHỐNG TRƯỢT - LỚP VỮA LÁT NỀN DÀY 30/75, TẠO ĐỐC I=2% VỀ LỖ THU NƯỚC - LỚP ĐÁT ĐÁP NỀN ĐÀM CHẶT - LỚP ĐÁT TỰ NHIÊN DỌN SẠCH 	<p>N6</p> <ul style="list-style-type: none"> - LÁT GỖ NHỰA COMPOSITE 140X25 - RÁI THANH ĐÁ KHOẢNG CÁCH 300 MM - LỚP VỮA LÁT NỀN DÀY 30/75, LỚP ĐÁT ĐÁP NỀN ĐÀM CHẶT - LỚP ĐÁT TỰ NHIÊN DỌN SẠCH 	<p>N7</p> <ul style="list-style-type: none"> - LÁT GẠCH HIỆU ỨNG BỀ MẶT 2 MÀU KIỂU THIẾT KẾ THEO MẪU - LỚP VỮA LÁT NỀN DÀY 30/75, - LỚP ĐÁT ĐÁP NỀN ĐÀM CHẶT - LỚP ĐÁT TỰ NHIÊN DỌN SẠCH
--	---	--	--	---	--	---



SCALE 1/120

FLOOR (TILED) PLAN 2

N1	N2	N3	N4	N5	N6	N7
<ul style="list-style-type: none"> - LÁT GẠCH GRANITE KT 800X800 MÀU GIA CHỦ LỰA CHỌN - LỚP VỮA LÁT NỀN DÀY $\frac{30}{75}$ - LỚP BÊ TÔNG ĐÁ (10X20), DÀY 100 - LỚP ĐÁT ĐÁP NỀN ĐẢM CHẶT - LỚP ĐÁT TỰ NHIÊN DỌN SẠCH 	<ul style="list-style-type: none"> - LÁT GỖ THANH 145X1200X8 - LỚP VỮA LÁT NỀN DÀY $\frac{30}{75}$ - LỚP BÊ TÔNG ĐÁ (10X20), DÀY 100 - LỚP ĐÁT ĐÁP NỀN ĐẢM CHẶT - LỚP ĐÁT TỰ NHIÊN DỌN SẠCH 	<ul style="list-style-type: none"> - LÁT GẠCH CERAMIC KT 300X300 MÀU GIA CHỦ TỰ CHỌN, CHỐNG TRƯỢT - LỚP VỮA LÁT NỀN DÀY $\frac{30}{75}$, TẠO ĐỐC I=2% VỀ LỖ THU NƯỚC - LỚP ĐÁT ĐÁP NỀN ĐẢM CHẶT - LỚP ĐÁT TỰ NHIÊN DỌN SẠCH 	<ul style="list-style-type: none"> - LÁT GẠCH GRANITE KT 800X800 MÀU GIA CHỦ LỰA CHỌN - LỚP VỮA LÁT NỀN DÀY $\frac{30}{75}$ - LỚP BÊ TÔNG ĐÁ (10X20), DÀY 100 - LỚP ĐÁT ĐÁP NỀN ĐẢM CHẶT - LỚP ĐÁT TỰ NHIÊN DỌN SẠCH 	<ul style="list-style-type: none"> - LÁT GẠCH MOSAIC CERAMIC KT 40X40 MÀU GIA CHỦ TỰ CHỌN, CHỐNG TRƯỢT - LỚP VỮA LÁT NỀN DÀY $\frac{30}{75}$, TẠO ĐỐC I=2% VỀ LỖ THU NƯỚC - LỚP ĐÁT ĐÁP NỀN ĐẢM CHẶT - LỚP ĐÁT TỰ NHIÊN DỌN SẠCH 	<ul style="list-style-type: none"> - LÁT GỖ NHỰA COMPOSITE 140X25 - RÁI THANH ĐÁ KHOẢNG CÁCH 300 MM - LỚP VỮA LÁT NỀN DÀY $\frac{30}{75}$, LỚP ĐÁT ĐÁP NỀN ĐẢM CHẶT - LỚP ĐÁT TỰ NHIÊN DỌN SẠCH 	<ul style="list-style-type: none"> - LÁT GẠCH HIỆU ỨNG BỀ MẶT 2 MÀU KIỂU THIẾT KẾ THEO MẪU - LỚP VỮA LÁT NỀN DÀY $\frac{30}{75}$ - LỚP ĐÁT ĐÁP NỀN ĐẢM CHẶT - LỚP ĐÁT TỰ NHIÊN DỌN SẠCH

CONTENTS

Intro

1. Site assessment | Brief
2. References
3. Design Concept diagrams

Proposal

/ A

4. Architecture/ Floor plan 1
5. Architecture/ Floor plan 1/ dimension
6. Architecture/ Floor plan 2
7. Architecture/ Floor plan 2/ dimension
8. Architecture/ Roof plan
9. Architecture/ Roof plan/ dimension
10. Architecture/ Elevations
11. Architecture/ Sections
12. Architecture/ Door details
13. Architecture/ 3D visualizations

/ B

14. Interior/ Floor (tiled) plan 1
15. Interior/ Floor (tiled) plan 2
16. Interior/ Ceiling plan 1
17. Interior/ Ceiling plan 2
18. Interior/ Lightning plan 1
19. Interior/ Lightning plan 2
20. Interior/ Outdoor Lightning plan
21. Interior/ Electrical plan 1
22. Interior/ Electrical plan 2
23. Interior/ Outdoor Electrical plan
24. Interior/ Power socket plan 1
25. Interior/ Power socket plan 2

/ C

26. Interior/ Kitchen
27. Interior/ Kitchen/ Furniture
28. Interior/ Living - dining spaces F1
29. Interior/ Common - praying spaces F2
30. Interior/ WC & furniture
31. Interior/ Bedroom & furniture
32. Exterior/ Outdoor spaces
33. Exterior/ Night view

/ D

34. Pattern/ Parametric design

/ E

35. Design process/ Experimentation & Iterations
36. Design process/ Methodology on information management

/ F

37. Remarks

 Page mark



SCALE 1/120
CEILINGPLAN 1

T1	T2	T3	T4
- TRẦN BTCT COS +4.000 SƠN NƯỚC MÀU TRẮNG	- TRẦN THẠCH CAO KHUNG CHÌM CHỐNG ẨM COS +3.900 - SƠN NƯỚC MÀU TRẮNG	- TRẦN BTCT COS +4.200 SƠN NƯỚC MÀU TRẮNG -	- TRẦN BTCT COS +3.900 SƠN NƯỚC MÀU TRẮNG

CONTENTS

Intro

1. Site assessment| Brief
2. References
3. Design Concept diagrams

Proposal

/ A

4. Architecture/ Floor plan 1
5. Architecture/ Floor plan 1/ dimension
6. Architecture/ Floor plan 2
7. Architecture/ Floor plan 2/ dimension
8. Architecture/ Roof plan
9. Architecture/ Roof plan/ dimension
10. Architecture/ Elevations
11. Architecture/ Sections
12. Architecture/ Door details
13. Architecture/ 3D visualizations

/ B

14. Interior/ Floor (tiled) plan 1
15. Interior/ Floor (tiled) plan 2
16. Interior/ Ceiling plan 1
17. Interior/ Ceiling plan 2
18. Interior/ Lightning plan 1
19. Interior/ Lightning plan 2
20. Interior/ Outdoor Lightning plan
21. Interior/ Electrical plan 1
22. Interior/ Electrical plan 2
23. Interior/ Outdoor Electrical plan
24. Interior/ Power socket plan 1
25. Interior/ Power socket plan 2

/ C

26. Interior/ Kitchen
27. Interior/ Kitchen/ Furniture
28. Interior/ Living - dining spaces F1
29. Interior/ Common - praying spaces F2
30. Interior/ WC & furniture
31. Interior/ Bedroom & furniture
32. Exterior/ Outdoor spaces
33. Exterior/ Night view

/ D

34. Pattern/ Parametric design

/ E

35. Design process/ Experimentation & Iterations
36. Design process/ Methodology on information management

/ F

37. Remarks

16 Page mark

CONTENTS

Intro

1. Site assessment | Brief
2. References
3. Design Concept diagrams

Proposal

/ A

4. Architecture/ Floor plan 1
5. Architecture/ Floor plan 1/ dimension
6. Architecture/ Floor plan 2
7. Architecture/ Floor plan 2/ dimension
8. Architecture/ Roof plan
9. Architecture/ Roof plan/ dimension
10. Architecture/ Elevations
11. Architecture/ Sections
12. Architecture/ Door details
13. Architecture/ 3D visualizations

/ B

14. Interior/ Floor (tiled) plan 1
15. Interior/ Floor (tiled) plan 2
16. Interior/ Ceiling plan 1
17. Interior/ Ceiling plan 2
18. Interior/ Lightning plan 1
19. Interior/ Lightning plan 2
20. Interior/ Outdoor Lightning plan
21. Interior/ Electrical plan 1
22. Interior/ Electrical plan 2
23. Interior/ Outdoor Electrical plan
24. Interior/ Power socket plan 1
25. Interior/ Power socket plan 2

/ C

26. Interior/ Kitchen
27. Interior/ Kitchen/ Furniture
28. Interior/ Living - dining spaces F1
29. Interior/ Common - praying spaces F2
30. Interior/ WC & furniture
31. Interior/ Bedroom & furniture
32. Exterior/ Outdoor spaces
33. Exterior/ Night view

/ D

34. Pattern/ Parametric design

/ E

35. Design process/ Experimentation & Iterations
36. Design process/ Methodology on information management

/ F

37. Remarks

 Page mark

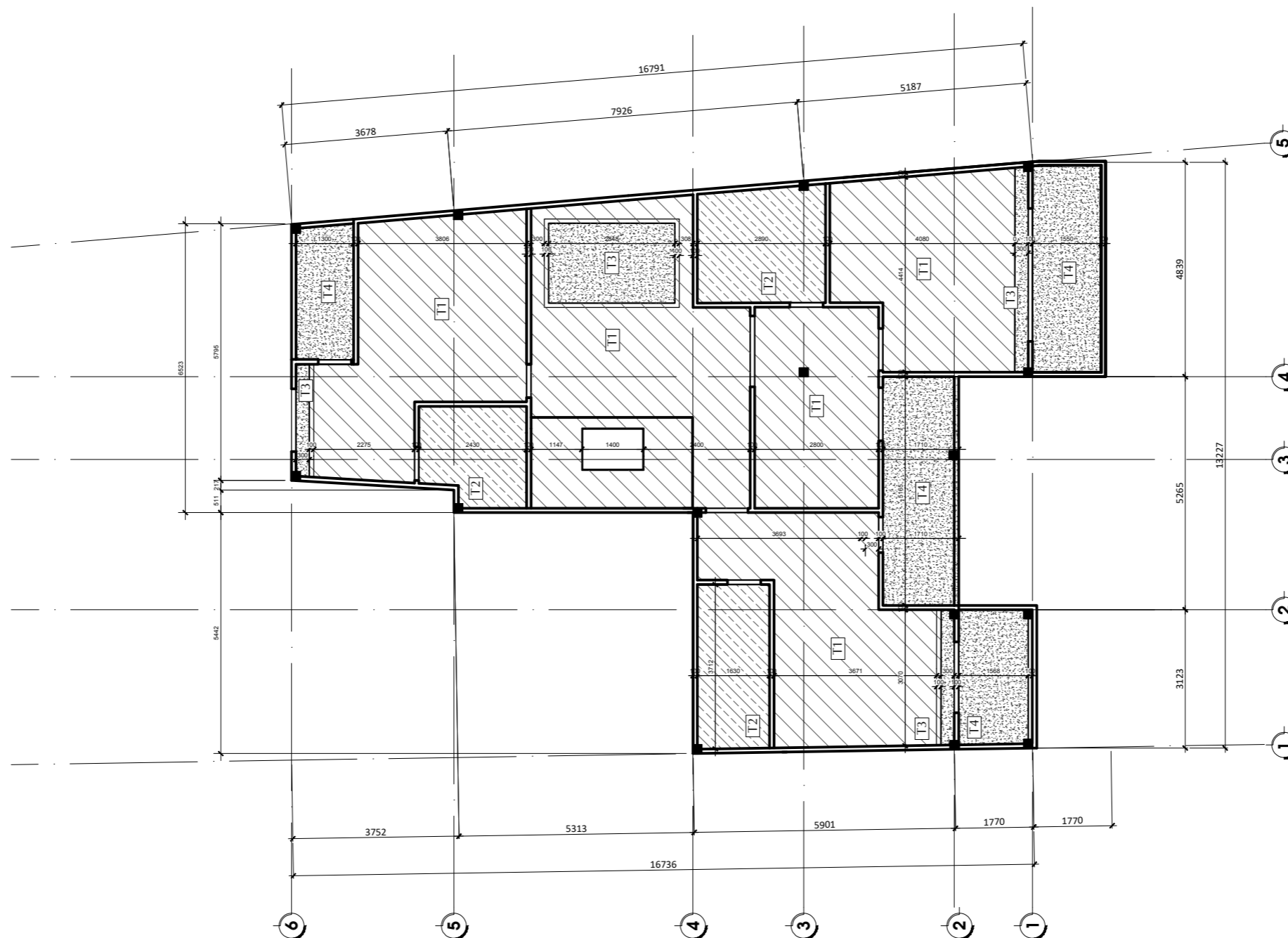

SCALE 1/120
CEILINGPLAN 2

T1	T2	T3	T4
- TRẦN BTCT COS +4.000 SƠN NƯỚC MÀU TRẮNG	- TRẦN THẠCH CAO KHUNG CHÌM CHỐNG ẨM COS +3.900 SƠN NƯỚC MÀU TRẮNG	- TRẦN BTCT COS +4.200 SƠN NƯỚC MÀU TRẮNG -	- TRẦN BTCT COS +3.900 SƠN NƯỚC MÀU TRẮNG

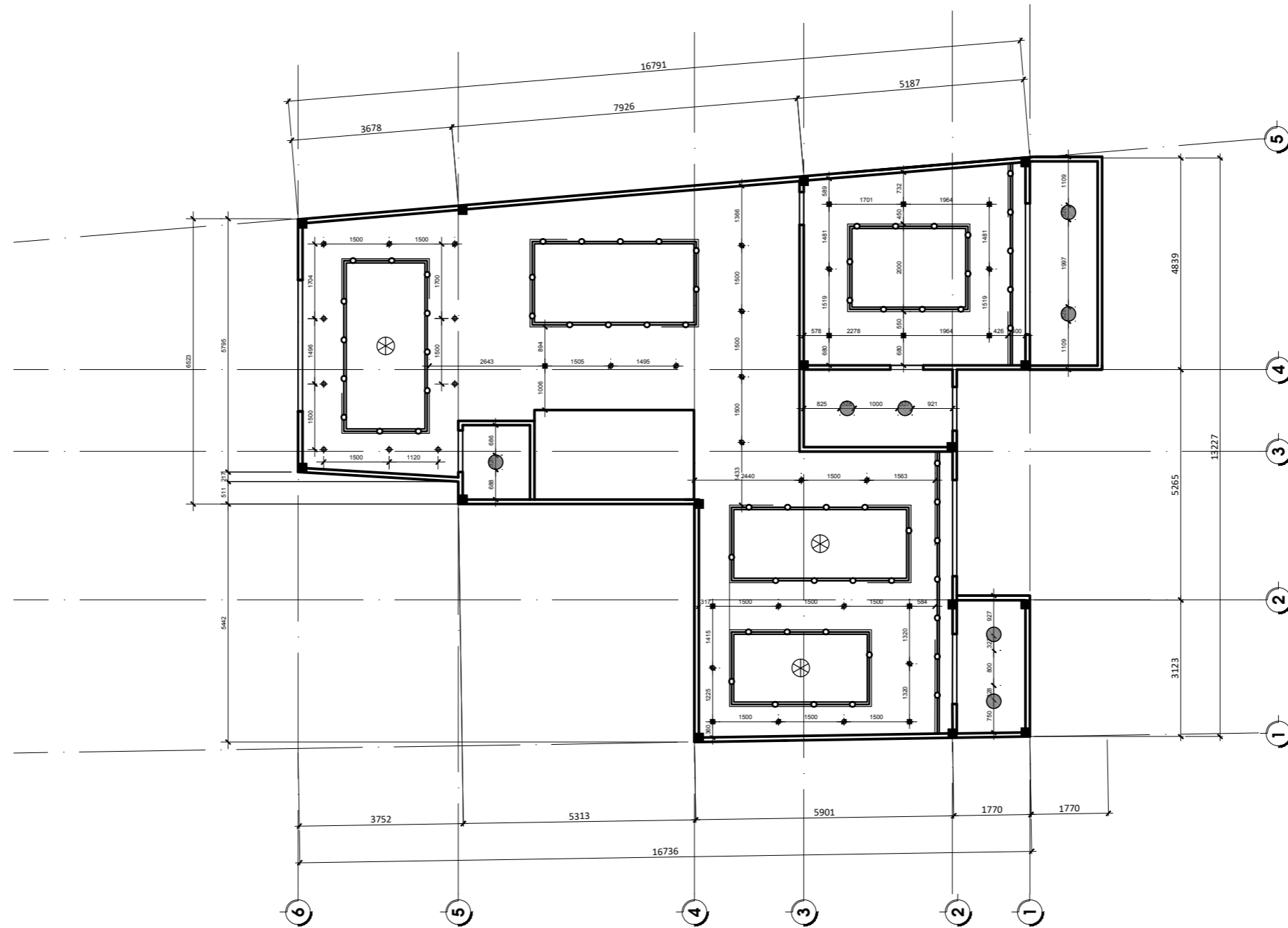

SCALE 1/120

LIGHTNING PLAN FLOOR 1

ĐÈN TƯỜNG	ĐÈN GƯƠNG	ĐÈN CHÙM	ĐÈN LED TRÒN PHI 90 ÂM MPE 12W 4000K	ĐÈN LED TRÒN PHI 90 ÂM MPE 12W 4000K

CONTENTS

Intro

1. Site assessment | Brief
2. References
3. Design Concept diagrams

Proposal

/ A

4. Architecture/ Floor plan 1
5. Architecture/ Floor plan 1/ dimension
6. Architecture/ Floor plan 2
7. Architecture/ Floor plan 2/ dimension
8. Architecture/ Roof plan
9. Architecture/ Roof plan/ dimension
10. Architecture/ Elevations
11. Architecture/ Sections
12. Architecture/ Door details
13. Architecture/ 3D visualizations

/ B

14. Interior/ Floor (tiled) plan 1
15. Interior/ Floor (tiled) plan 2
16. Interior/ Ceiling plan 1
17. Interior/ Ceiling plan 2
18. Interior/ Lightning plan 1
19. Interior/ Lightning plan 2
20. Interior/ Outdoor Lightning plan
21. Interior/ Electrical plan 1
22. Interior/ Electrical plan 2
23. Interior/ Outdoor Electrical plan
24. Interior/ Power socket plan 1
25. Interior/ Power socket plan 2

/ C

26. Interior/ Kitchen
27. Interior/ Kitchen/ Furniture
28. Interior/ Living - dining spaces F1
29. Interior/ Common - praying spaces F2
30. Interior/ WC & furniture
31. Interior/ Bedroom & furniture
32. Exterior/ Outdoor spaces
33. Exterior/ Night view

/ D

34. Pattern/ Parametric design

/ E

35. Design process/ Experimentation & Iterations
36. Design process/ Methodology on information management

/ F

37. Remarks

Page mark

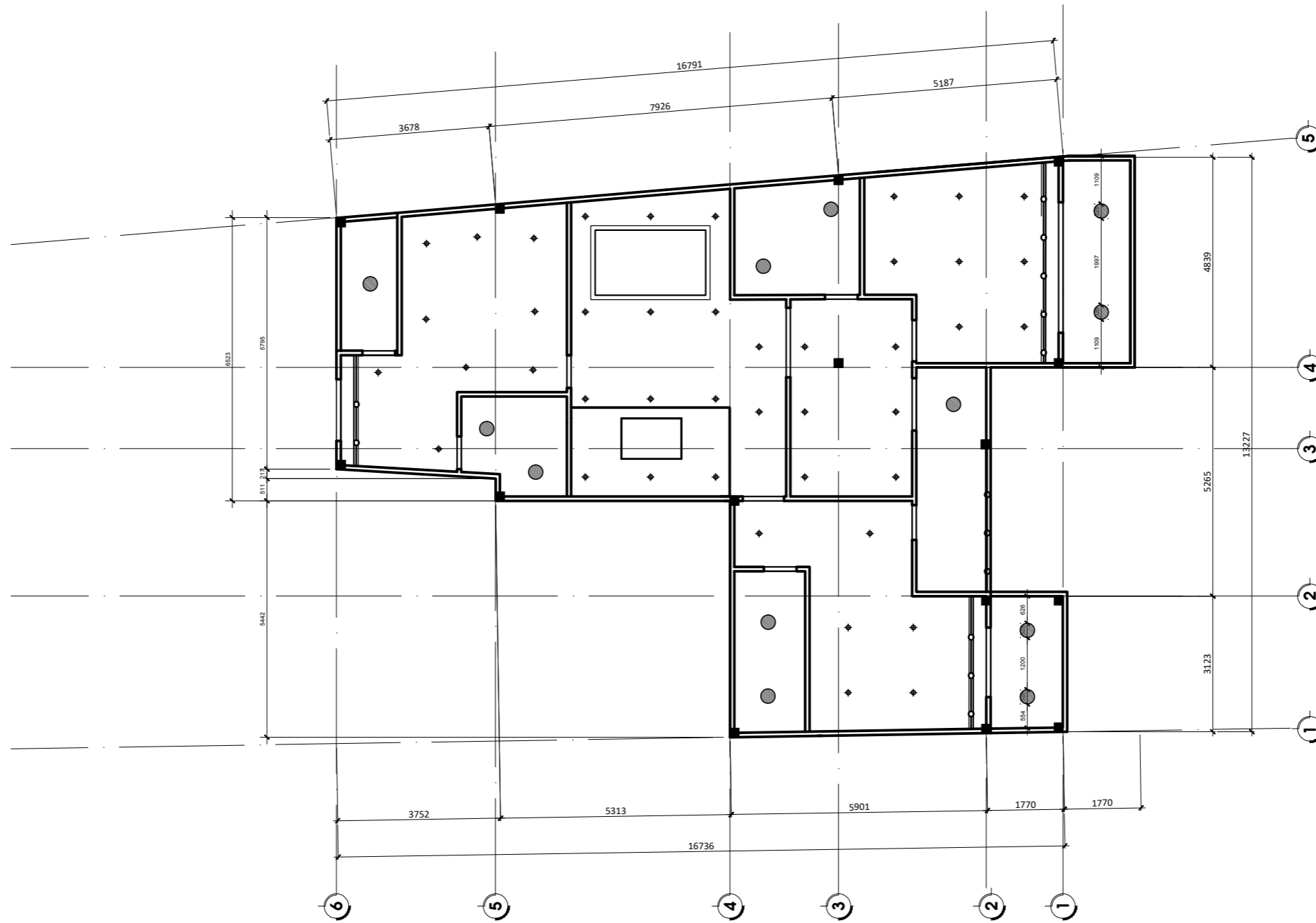

CONTENTS

Intro

- 1. Site assessment| Brief
- 2. References
- 3. Design Concept diagrams

Proposal

/ A

- 4. Architecture/ Floor plan 1
- 5. Architecture/ Floor plan 1/ dimension
- 6. Architecture/ Floor plan 2
- 7. Architecture/ Floor plan 2/ dimension
- 8. Architecture/ Roof plan
- 9. Architecture/ Roof plan/ dimension
- 10. Architecture/ Elevations
- 11. Architecture/ Sections
- 12. Architecture/ Door details
- 13. Architecture/ 3D visualizations

/ B

- 14. Interior/ Floor (tiled) plan 1
- 15. Interior/ Floor (tiled) plan 2
- 16. Interior/ Ceiling plan 1
- 17. Interior/ Ceiling plan 2
- 18. Interior/ Lightning plan 1
- 19. Interior/ Lightning plan 2
- 20. Interior/ Outdoor Lightning plan
- 21. Interior/ Electrical plan 1
- 22. Interior/ Electrical plan 2
- 23. Interior/ Outdoor Electrical plan
- 24. Interior/ Power socket plan 1
- 25. Interior/ Power socket plan 2

/ C

- 26. Interior/ Kitchen
- 27. Interior/ Kitchen/ Furniture
- 28. Interior/ Living - dining spaces F1
- 29. Interior/ Common - praying spaces F2
- 30. Interior/ WC & furniture
- 31. Interior/ Bedroom & furniture
- 32. Exterior/ Outdoor spaces
- 33. Exterior/ Night view

/ D

- 34. Pattern/ Parametric design

/ E

- 35. Design process/ Experimentation & Iterations
- 36. Design process/ Methodology on information management

/ F

- 37. Remarks

 Page mark



SCALE 1/120

LIGHTNING PLAN FLOOR 2

ĐÈN TƯỜNG	ĐÈN GƯƠNG	ĐÈN CHÙM	ĐÈN LED TRÒN PHI 90 ÂM MPE 12W 4000K	ĐÈN LED TRÒN PHI 90 ÂM MPE 12W 4000K

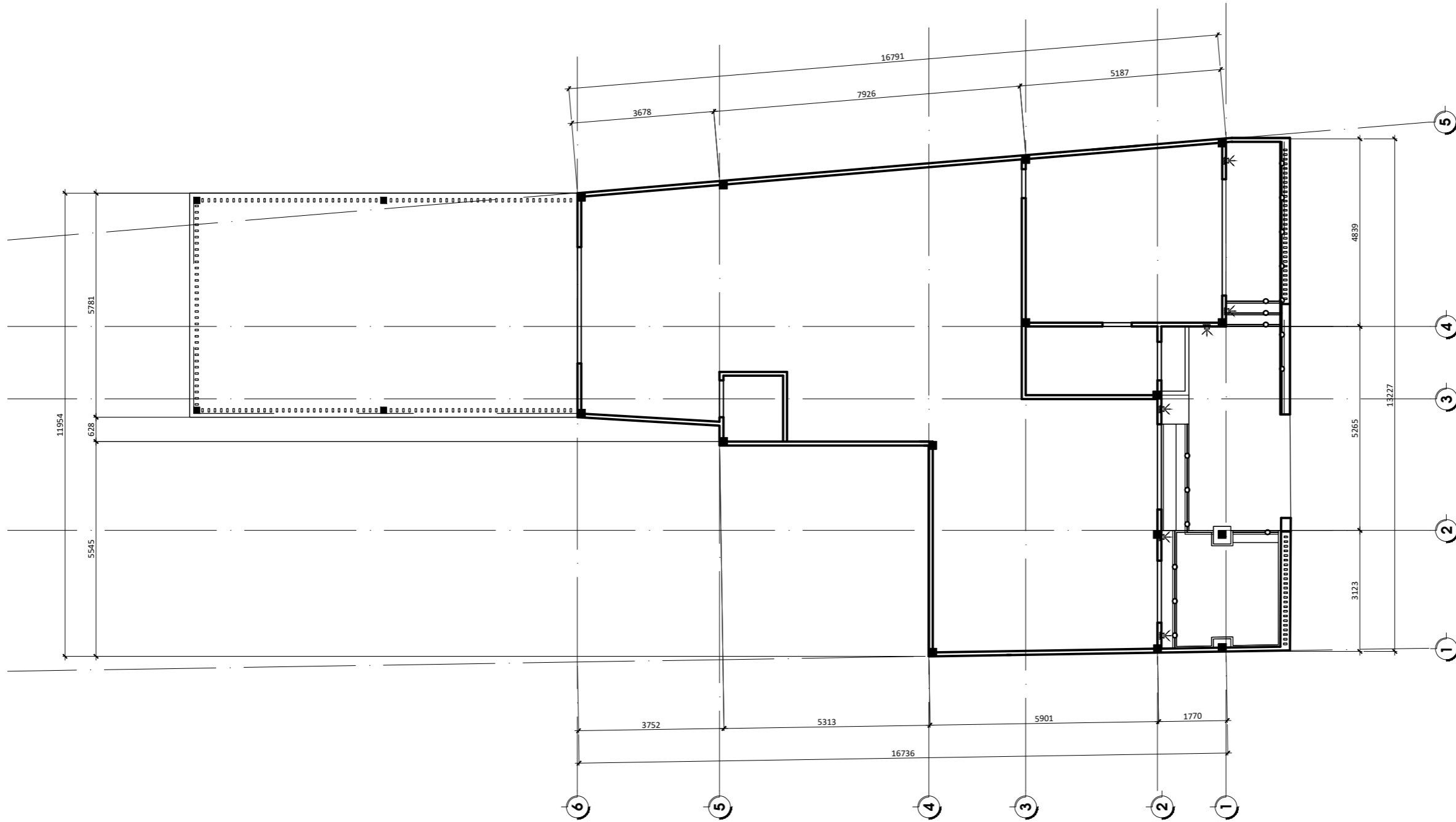

SCALE 1/120

LIGHTNING PLAN OUTDOOR

ĐÈN TƯỜNG	ĐÈN GƯƠNG	ĐÈN CHÙM	ĐÈN LED TRÒN PHI 90 ÂM MPE 12W 4000K	ĐÈN LED TRÒN PHI 90 ÂM MPE 12W 4000K

CONTENTS

Intro

1. Site assessment| Brief
2. References
3. Design Concept diagrams

Proposal

/ A

4. Architecture/ Floor plan 1
5. Architecture/ Floor plan 1/ dimension
6. Architecture/ Floor plan 2
7. Architecture/ Floor plan 2/ dimension
8. Architecture/ Roof plan
9. Architecture/ Roof plan/ dimension
10. Architecture/ Elevations
11. Architecture/ Sections
12. Architecture/ Door details
13. Architecture/ 3D visualizations

/ B

14. Interior/ Floor (tiled) plan 1
15. Interior/ Floor (tiled) plan 2
16. Interior/ Ceiling plan 1
17. Interior/ Ceiling plan 2
18. Interior/ Lightning plan 1
19. Interior/ Lightning plan 2
20. Interior/ Outdoor Lightning plan
21. Interior/ Electrical plan 1
22. Interior/ Electrical plan 2
23. Interior/ Outdoor Electrical plan
24. Interior/ Power socket plan 1
25. Interior/ Power socket plan 2

/ C

26. Interior/ Kitchen
27. Interior/ Kitchen/ Furniture
28. Interior/ Living - dining spaces F1
29. Interior/ Common - praying spaces F2
30. Interior/ WC & furniture
31. Interior/ Bedroom & furniture
32. Exterior/ Outdoor spaces
33. Exterior/ Night view

/ D

34. Pattern/ Parametric design

/ E

35. Design process/ Experimentation & Iterations
36. Design process/ Methodology on information management

/ F

37. Remarks

Page mark

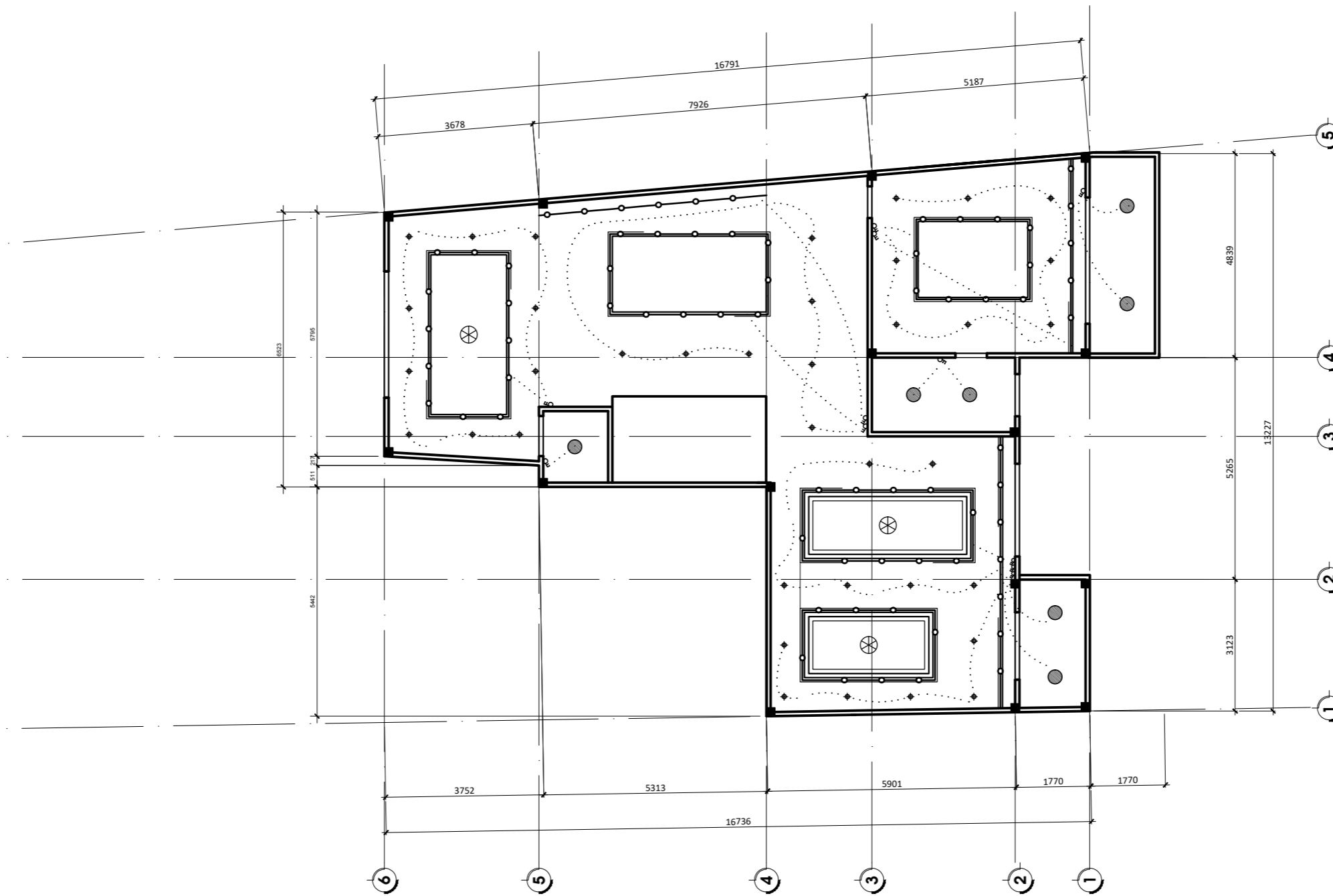

CONTENTS

Intro

1. Site assessment| Brief
2. References
3. Design Concept diagrams

Proposal

/ A

4. Architecture/ Floor plan 1
5. Architecture/ Floor plan 1/ dimension
6. Architecture/ Floor plan 2
7. Architecture/ Floor plan 2/ dimension
8. Architecture/ Roof plan
9. Architecture/ Roof plan/ dimension
10. Architecture/ Elevations
11. Architecture/ Sections
12. Architecture/ Door details
13. Architecture/ 3D visualizations

/ B

14. Interior/ Floor (tiled) plan 1
15. Interior/ Floor (tiled) plan 2
16. Interior/ Ceiling plan 1
17. Interior/ Ceiling plan 2
18. Interior/ Lightning plan 1
19. Interior/ Lightning plan 2
20. Interior/ Outdoor Lightning plan
21. Interior/ Electrical plan 1
22. Interior/ Electrical plan 2
23. Interior/ Outdoor Electrical plan
24. Interior/ Power socket plan 1
25. Interior/ Power socket plan 2

/ C

26. Interior/ Kitchen
27. Interior/ Kitchen/ Furniture
28. Interior/ Living - dining spaces F1
29. Interior/ Common - praying spaces F2
30. Interior/ WC & furniture
31. Interior/ Bedroom & furniture
32. Exterior/ Outdoor spaces
33. Exterior/ Night view

/ D

34. Pattern/ Parametric design

/ E

35. Design process/ Experimentation & Iterations
36. Design process/ Methodology on information management

/ F

37. Remarks

○ Page mark



SCALE 1/120

ELECTRICAL PLAN FLOOR 1

DÈN TƯỜNG	DÈN GIƯỜNG	DÈN CHÙM	DÈN LED TRÒN PHI 55 ẨM MPE 12W 4000K



CONTENTS

Intro

1. Site assessment| Brief
2. References
3. Design Concept diagrams

Proposal

/ A

4. Architecture/ Floor plan 1
5. Architecture/ Floor plan 1/ dimension
6. Architecture/ Floor plan 2
7. Architecture/ Floor plan 2/ dimension
8. Architecture/ Roof plan
9. Architecture/ Roof plan/ dimension
10. Architecture/ Elevations
11. Architecture/ Sections
12. Architecture/ Door details
13. Architecture/ 3D visualizations

/ B

14. Interior/ Floor (tiled) plan 1
15. Interior/ Floor (tiled) plan 2
16. Interior/ Ceiling plan 1
17. Interior/ Ceiling plan 2
18. Interior/ Lightning plan 1
19. Interior/ Lightning plan 2
20. Interior/ Outdoor Lightning plan
21. Interior/ Electrical plan 1
22. Interior/ Electrical plan 2
23. Interior/ Outdoor Electrical plan
24. Interior/ Power socket plan 1
25. Interior/ Power socket plan 2

/ C

26. Interior/ Kitchen
27. Interior/ Kitchen/ Furniture
28. Interior/ Living - dining spaces F1
29. Interior/ Common - praying spaces F2
30. Interior/ WC & furniture
31. Interior/ Bedroom & furniture
32. Exterior/ Outdoor spaces
33. Exterior/ Night view

/ D

34. Pattern/ Parametric design

/ E

35. Design process/ Experimentation & Iterations
36. Design process/ Methodology on information management

/ F

37. Remarks

○ Page mark



SCALE 1/120
ELECTRICAL PLAN FLOOR 2

DÈN TƯỜNG	DÈN GIƯƠNG	DÈN CHÙM	DÈN LED TRÒN PHI 55 AM MPE 12W 4000K

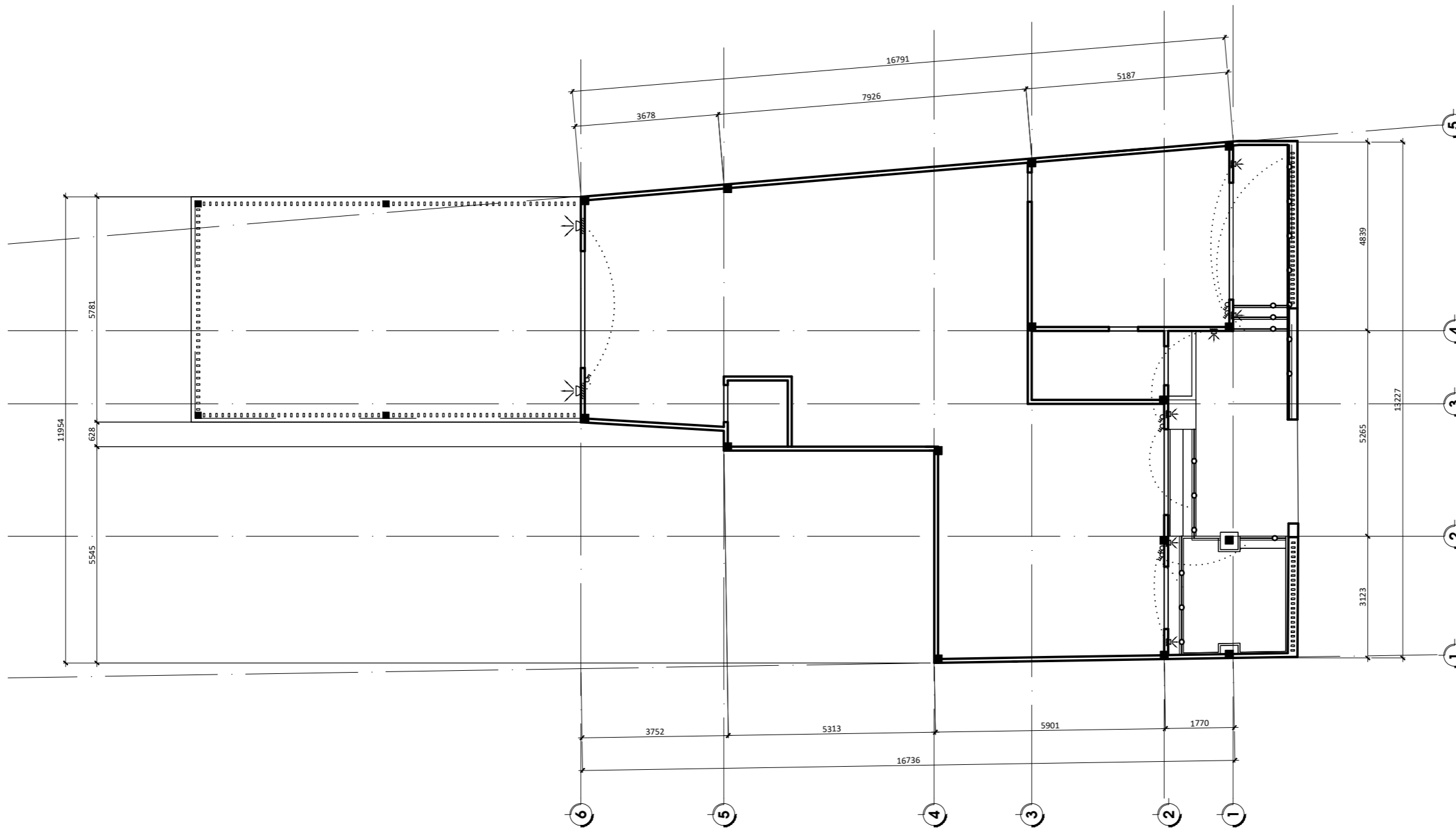

CONTENTS

Intro

1. Site assessment| Brief
2. References
3. Design Concept diagrams

Proposal

/ A

4. Architecture/ Floor plan 1
5. Architecture/ Floor plan 1/ dimension
6. Architecture/ Floor plan 2
7. Architecture/ Floor plan 2/ dimension
8. Architecture/ Roof plan
9. Architecture/ Roof plan/ dimension
10. Architecture/ Elevations
11. Architecture/ Sections
12. Architecture/ Door details
13. Architecture/ 3D visualizations

/ B

14. Interior/ Floor (tiled) plan 1
15. Interior/ Floor (tiled) plan 2
16. Interior/ Ceiling plan 1
17. Interior/ Ceiling plan 2
18. Interior/ Lightning plan 1
19. Interior/ Lightning plan 2
20. Interior/ Outdoor Lightning plan
21. Interior/ Electrical plan 1
22. Interior/ Electrical plan 2
23. Interior/ Outdoor Electrical plan
24. Interior/ Power socket plan 1
25. Interior/ Power socket plan 2

/ C

26. Interior/ Kitchen
27. Interior/ Kitchen/ Furniture
28. Interior/ Living - dining spaces F1
29. Interior/ Common - praying spaces F2
30. Interior/ WC & furniture
31. Interior/ Bedroom & furniture
32. Exterior/ Outdoor spaces
33. Exterior/ Night view

/ D

34. Pattern/ Parametric design

/ E

35. Design process/ Experimentation & Iterations
36. Design process/ Methodology on information management

/ F

37. Remarks

○ Page mark



SCALE 1/120

ELECTRICAL PLAN OUTDOOR

ĐÈN TƯỜNG	ĐÈN GƯƠNG	ĐÈN CHÙM	ĐÈN LED TRÒN PHI 55 AM MPE 12W 4000K

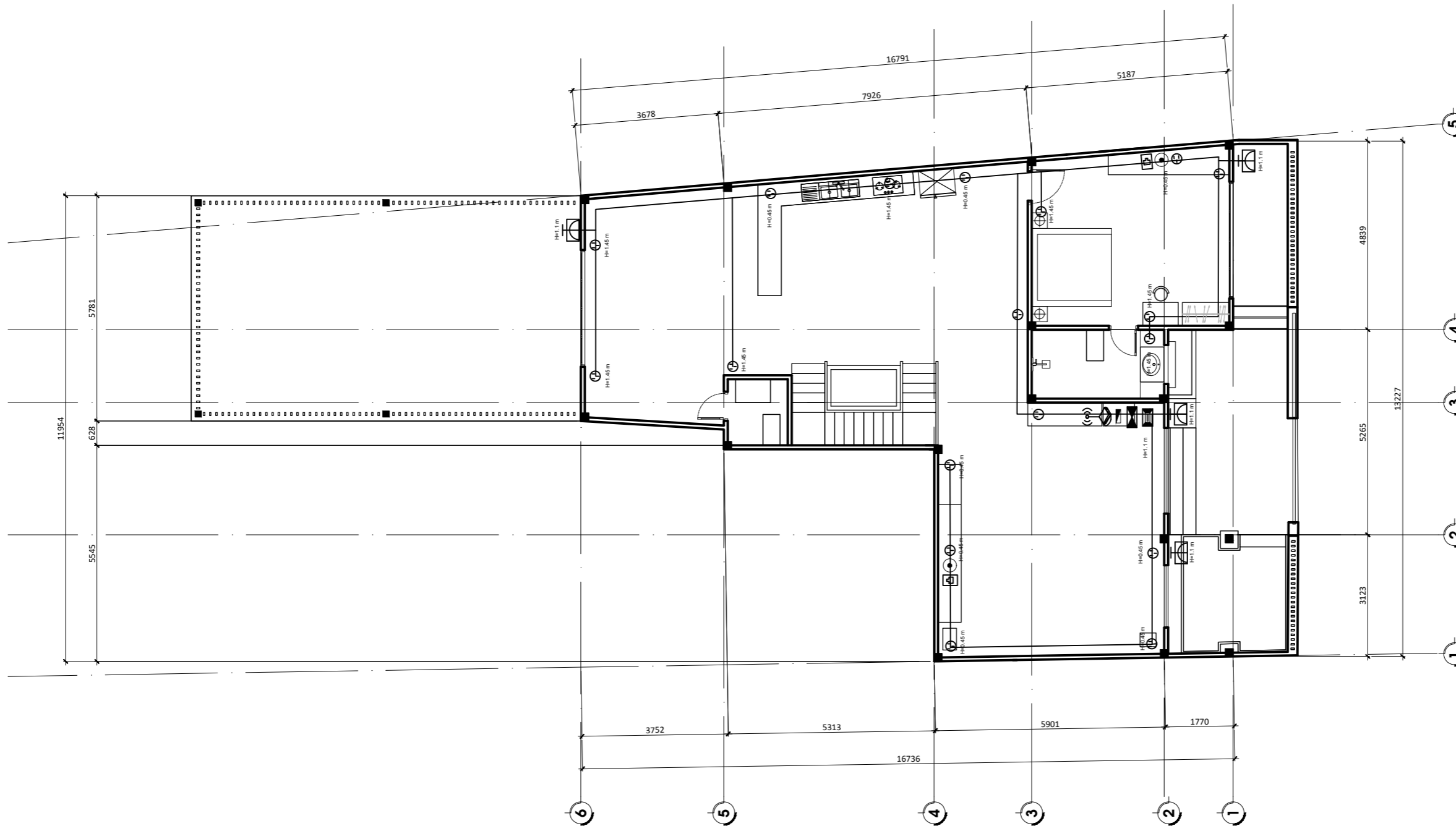

SCALE 1/120

POWER SOCKET PLAN FLOOR 1

	KÝ HIỆU HỆ THỐNG Ổ CẮM		Ổ CẮM CABLE TIVI CÙNG CAO ĐỘ VỚI MẶT NA Ổ CẮM TẠI CÙNG VỊ TRÍ
⊕	Ổ CẮM ẨM TƯỜNG, CAO ĐỘ LẮP ĐẶT +0.3m TÍNH ĐẾN CHÂN MẶT NA	⊕	Ổ CẮM CABLE ĐIỆN THOẠI CÙNG CAO ĐỘ VỚI MẶT NA Ổ CẮM TẠI CÙNG VỊ TRÍ
⊕	Ổ CẮM ẨM TƯỜNG, CAO ĐỘ LẮP ĐẶT +1.30m TÍNH ĐẾN CHÂN MẶT NA	⊕	MODEM WIFI CÙNG CAO ĐỘ VỚI MẶT NA Ổ CẮM TẠI CÙNG VỊ TRÍ
⊕	Ổ CẮM CABLE ADSL CÙNG CAO ĐỘ VỚI MẶT NA Ổ CẮM TẠI CÙNG VỊ TRÍ	⊕	TỦ ĐIỆN PHÂN PHỐI CHÍNH
⊕	CP	⊕	TỦ ĐIỆN PHÂN PHỐI TẮNG
⊕	Ổ CẮM 3 CHỐNG NƯỚC NGOÀI TRỜI		

CONTENTS

Intro

1. Site assessment | Brief
2. References
3. Design Concept diagrams

Proposal

/ A

4. Architecture/ Floor plan 1
5. Architecture/ Floor plan 1/ dimension
6. Architecture/ Floor plan 2
7. Architecture/ Floor plan 2/ dimension
8. Architecture/ Roof plan
9. Architecture/ Roof plan/ dimension
10. Architecture/ Elevations
11. Architecture/ Sections
12. Architecture/ Door details
13. Architecture/ 3D visualizations

/ B

14. Interior/ Floor (tiled) plan 1
15. Interior/ Floor (tiled) plan 2
16. Interior/ Ceiling plan 1
17. Interior/ Ceiling plan 2
18. Interior/ Lightning plan 1
19. Interior/ Lightning plan 2
20. Interior/ Outdoor Lightning plan
21. Interior/ Electrical plan 1
22. Interior/ Electrical plan 2
23. Interior/ Outdoor Electrical plan
24. Interior/ Power socket plan 1
25. Interior/ Power socket plan 2

/ C

26. Interior/ Kitchen
27. Interior/ Kitchen/ Furniture
28. Interior/ Living - dining spaces F1
29. Interior/ Common - praying spaces F2
30. Interior/ WC & furniture
31. Interior/ Bedroom & furniture
32. Exterior/ Outdoor spaces
33. Exterior/ Night view

/ D

34. Pattern/ Parametric design

/ E

35. Design process/ Experimentation & Iterations
36. Design process/ Methodology on information management

/ F

37. Remarks

○ Page mark



SCALE 1/120

POWER SOCKET PLAN FLOOR 2

	KÝ HIỆU HỆ THỐNG Ổ CẮM		Ổ CẮM CABLE TIVI CÙNG CAO ĐỘ VỚI MẶT NA Ổ CẮM TẠI CÙNG VỊ TRÍ
⊕	Ổ CẮM ẨM TƯỜNG, CAO ĐỘ LẮP ĐẶT +0.3m TÍNH ĐẾN CHÂN MẶT NA	☎	Ổ CẮM CABLE ĐIỆN THOẠI CÙNG CAO ĐỘ VỚI MẶT NA Ổ CẮM TẠI CÙNG VỊ TRÍ
⊕	Ổ CẮM ẨM TƯỜNG, CAO ĐỘ LẮP ĐẶT +1.30m TÍNH ĐẾN CHÂN MẶT NA	📶	MODEM WIFI CÙNG CAO ĐỘ VỚI MẶT NA Ổ CẮM TẠI CÙNG VỊ TRÍ
⊕	Ổ CẮM CABLE ADSL CÙNG CAO ĐỘ VỚI MẶT NA Ổ CẮM TẠI CÙNG VỊ TRÍ	⚡	TỦ ĐIỆN PHÂN PHỐI CHÍNH
⊕	CP	⚡	TỦ ĐIỆN PHÂN PHỐI TẦNG
☔	Ổ CẮM 3 CHỐNG NƯỚC NGOÀI TRỜI		

CONTENTS

Intro

1. Site assessment | Brief
2. References
3. Design Concept diagrams

Proposal

/ A

4. Architecture/ Floor plan 1
5. Architecture/ Floor plan 1/ dimension
6. Architecture/ Floor plan 2
7. Architecture/ Floor plan 2/ dimension
8. Architecture/ Roof plan
9. Architecture/ Roof plan/ dimension
10. Architecture/ Elevations
11. Architecture/ Sections
12. Architecture/ Door details
13. Architecture/ 3D visualizations

/ B

14. Interior/ Floor (tiled) plan 1
15. Interior/ Floor (tiled) plan 2
16. Interior/ Ceiling plan 1
17. Interior/ Ceiling plan 2
18. Interior/ Lightning plan 1
19. Interior/ Lightning plan 2
20. Interior/ Outdoor Lightning plan
21. Interior/ Electrical plan 1
22. Interior/ Electrical plan 2
23. Interior/ Outdoor Electrical plan
24. Interior/ Power socket plan 1
25. Interior/ Power socket plan 2

/ C

26. Interior/ Kitchen
27. Interior/ Kitchen/ Furniture
28. Interior/ Living - dining spaces F1
29. Interior/ Common - praying spaces F2
30. Interior/ WC & furniture
31. Interior/ Bedroom & furniture
32. Exterior/ Outdoor spaces
33. Exterior/ Night view

/ D

34. Pattern/ Parametric design

/ E

35. Design process/ Experimentation & Iterations
36. Design process/ Methodology on information management

/ F

37. Remarks

○ Page mark



CONTENTS

Intro

1. Site assessment | Brief
2. References
3. Design Concept diagrams

Proposal

/ A

4. Architecture/ Floor plan 1
5. Architecture/ Floor plan 1/ dimension
6. Architecture/ Floor plan 2
7. Architecture/ Floor plan 2/ dimension
8. Architecture/ Roof plan
9. Architecture/ Roof plan/ dimension
10. Architecture/ Elevations
11. Architecture/ Sections
12. Architecture/ Door details
13. Architecture/ 3D visualizations

/ B

14. Interior/ Floor (tiled) plan 1
15. Interior/ Floor (tiled) plan 2
16. Interior/ Ceiling plan 1
17. Interior/ Ceiling plan 2
18. Interior/ Lightning plan 1
19. Interior/ Lightning plan 2
20. Interior/ Outdoor Lightning plan
21. Interior/ Electrical plan 1
22. Interior/ Electrical plan 2
23. Interior/ Outdoor Electrical plan
24. Interior/ Power socket plan 1
25. Interior/ Power socket plan 2

/ C

26. Interior/ Kitchen
27. Interior/ Kitchen/ Furniture
28. Interior/ Living - dining spaces F1
29. Interior/ Common - praying spaces F2
30. Interior/ WC & furniture
31. Interior/ Bedroom & furniture
32. Exterior/ Outdoor spaces
33. Exterior/ Night view

/ D

34. Pattern/ Parametric design

/ E

35. Design process/ Experimentation & Iterations
36. Design process/ Methodology on information management

/ F

37. Remarks

26 Page mark

3D VISUALIZATION

KITCHEN & DINING SPACES

5

4

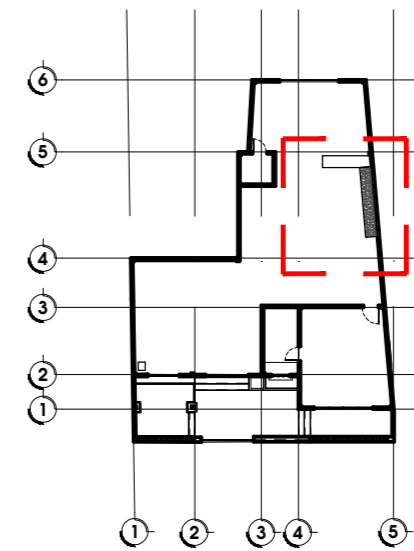
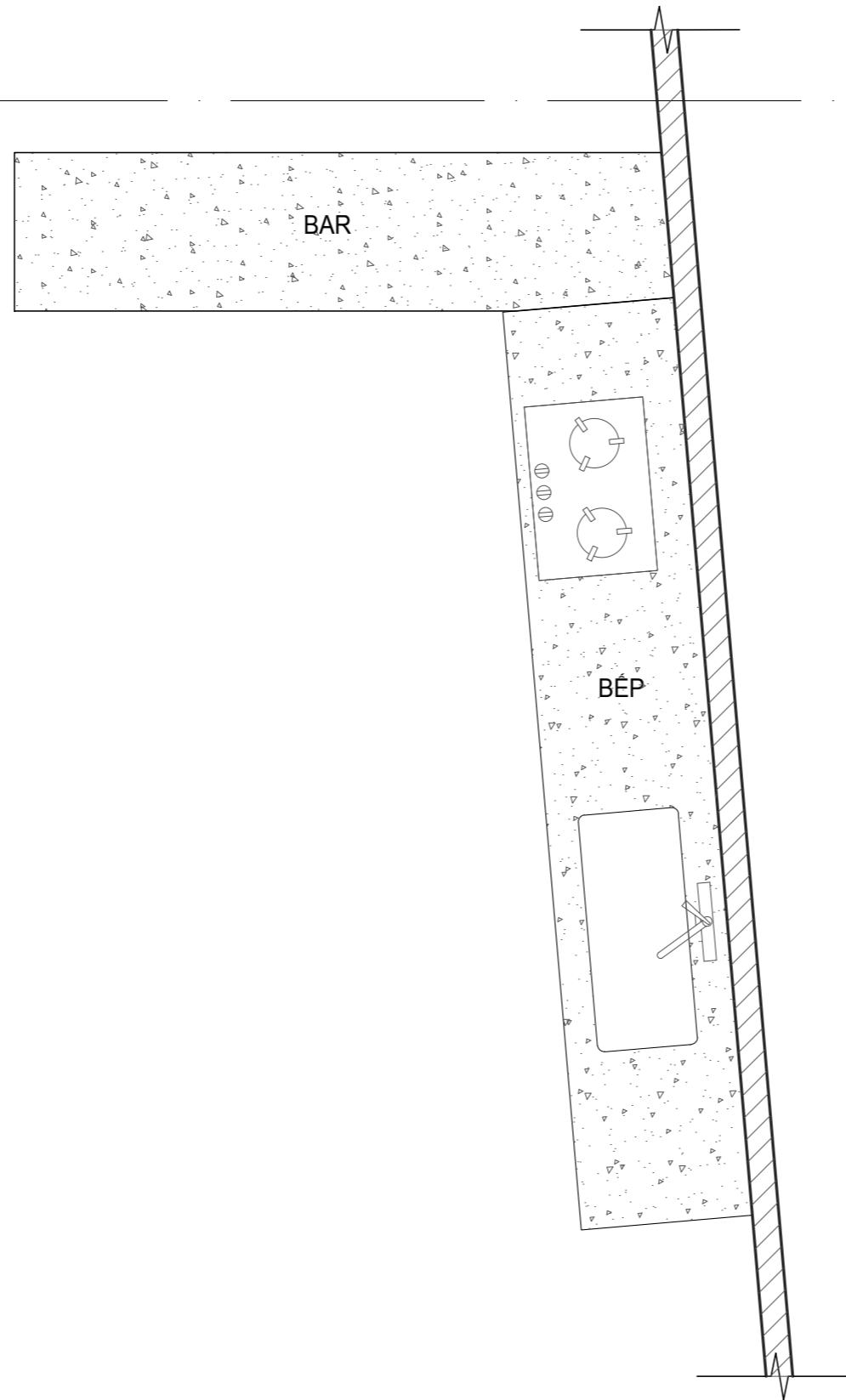

VỊ TRÍ

CONTENTS

Intro

1. Site assessment | Brief
2. References
3. Design Concept diagrams

Proposal

/ A

4. Architecture/ Floor plan 1
5. Architecture/ Floor plan 1/ dimension
6. Architecture/ Floor plan 2
7. Architecture/ Floor plan 2/ dimension
8. Architecture/ Roof plan
9. Architecture/ Roof plan/ dimension
10. Architecture/ Elevations
11. Architecture/ Sections
12. Architecture/ Door details
13. Architecture/ 3D visualizations

/ B

14. Interior/ Floor (tiled) plan 1
15. Interior/ Floor (tiled) plan 2
16. Interior/ Ceiling plan 1
17. Interior/ Ceiling plan 2
18. Interior/ Lightning plan 1
19. Interior/ Lightning plan 2
20. Interior/ Outdoor Lightning plan
21. Interior/ Electrical plan 1
22. Interior/ Electrical plan 2
23. Interior/ Outdoor Electrical plan
24. Interior/ Power socket plan 1
25. Interior/ Power socket plan 2

/ C

26. Interior/ Kitchen
27. Interior/ Kitchen/ Furniture
28. Interior/ Living - dining spaces F1
29. Interior/ Common - praying spaces F2
30. Interior/ WC & furniture
31. Interior/ Bedroom & furniture
32. Exterior/ Outdoor spaces
33. Exterior/ Night view

/ D

34. Pattern/ Parametric design

/ E

35. Design process/ Experimentation & Iterations
36. Design process/ Methodology on information management

/ F

37. Remarks

Page mark

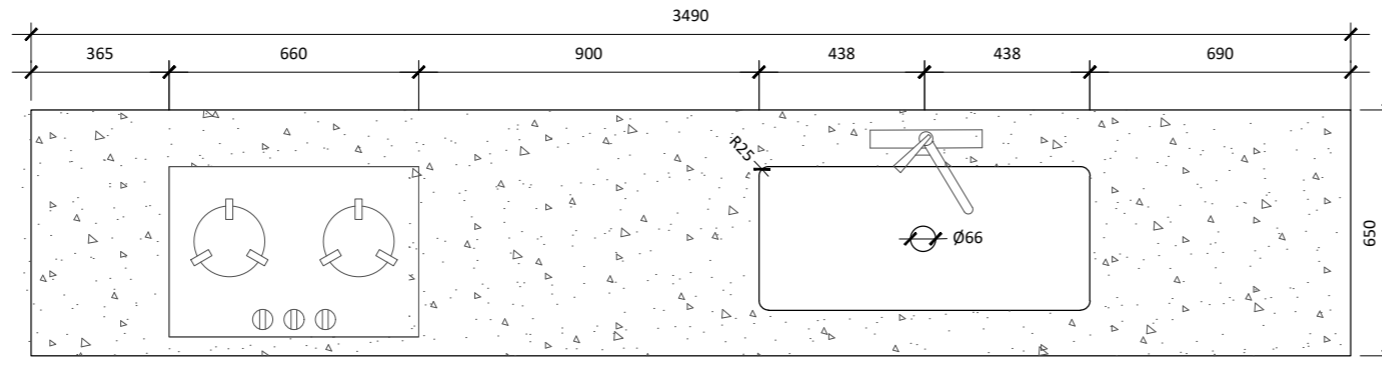

MẶT BẰNG TL 1/20

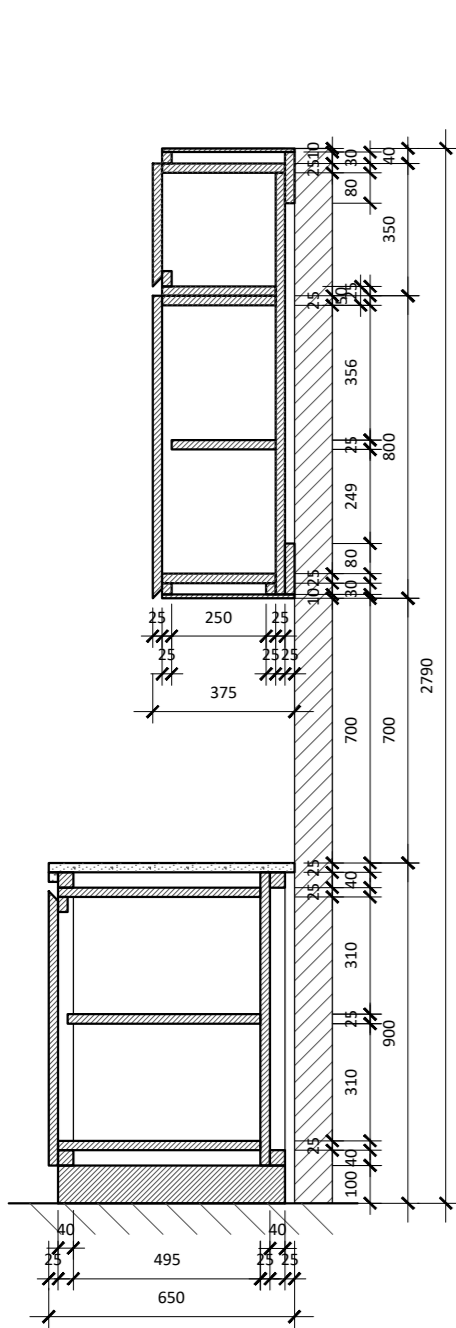

MẶT CẮT B-B' TL 1/20

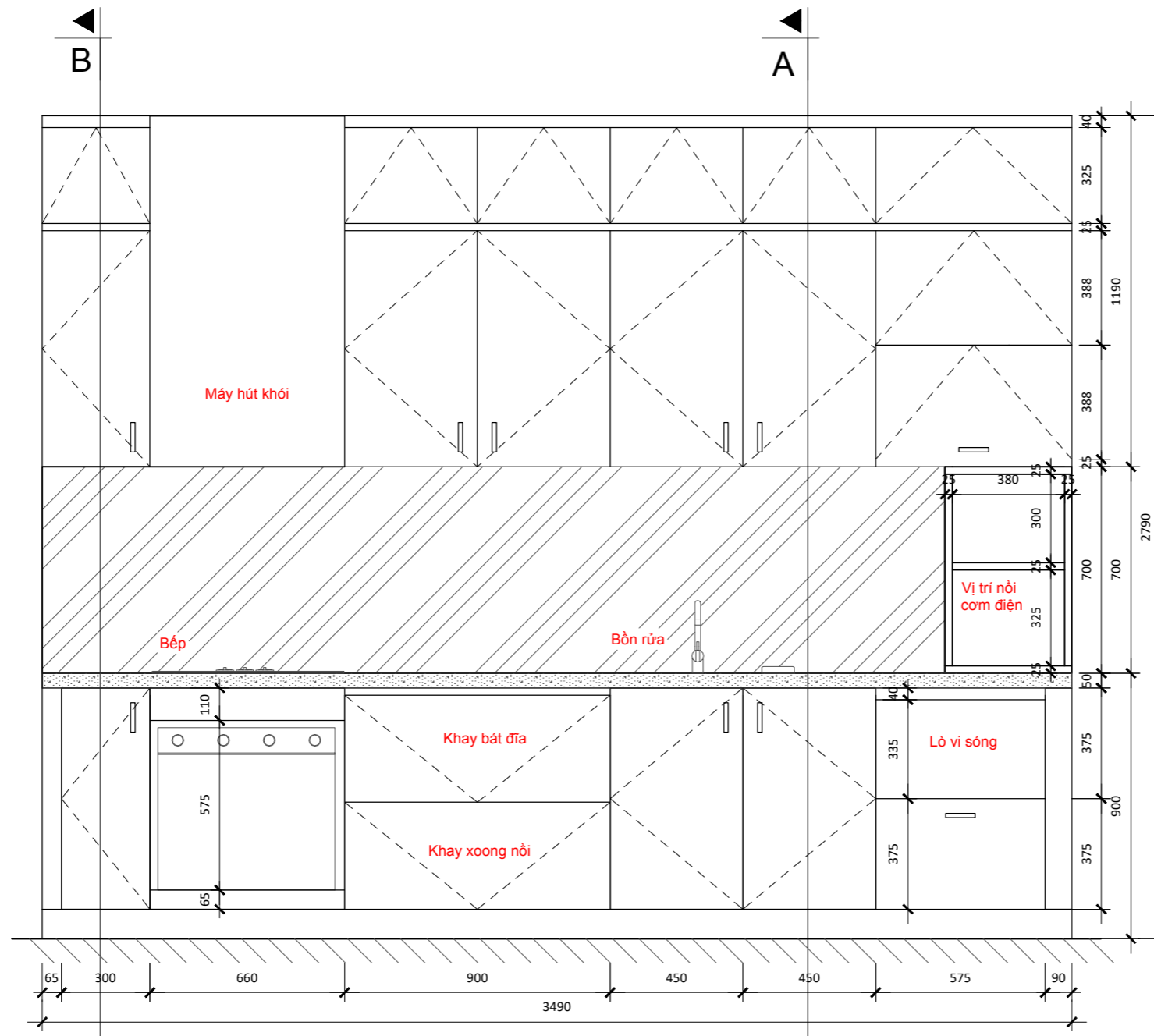

MẶT ĐỨNG TRƯỚC 1/20

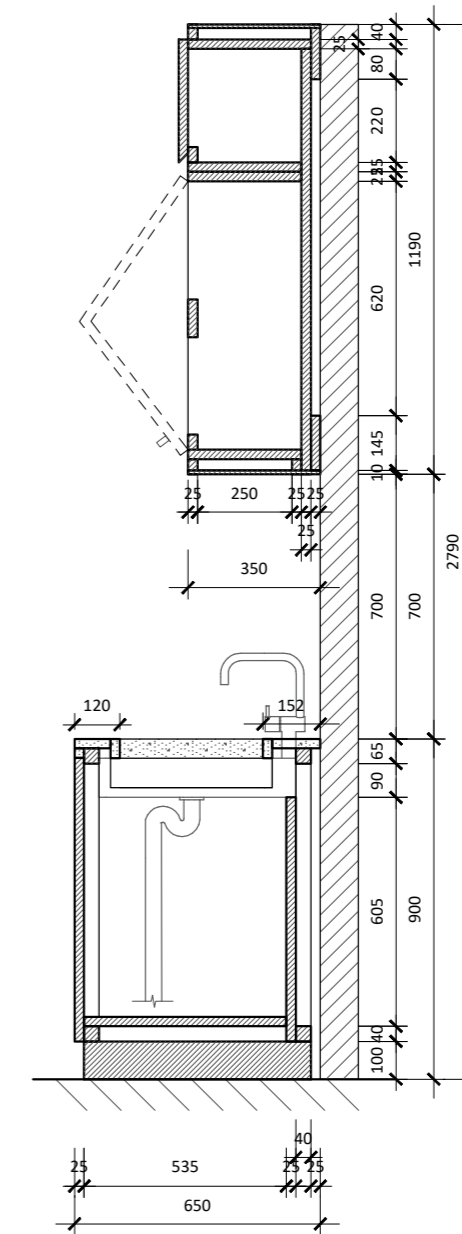

MẶT CẮT A-A' TL 1/20

CONTENTS

Intro

1. Site assessment | Brief
2. References
3. Design Concept diagrams

Proposal

/ A

4. Architecture/ Floor plan 1
5. Architecture/ Floor plan 1/ dimension
6. Architecture/ Floor plan 2
7. Architecture/ Floor plan 2/ dimension
8. Architecture/ Roof plan
9. Architecture/ Roof plan/ dimension
10. Architecture/ Elevations
11. Architecture/ Sections
12. Architecture/ Door details
13. Architecture/ 3D visualizations

/ B

14. Interior/ Floor (tiled) plan 1
15. Interior/ Floor (tiled) plan 2
16. Interior/ Ceiling plan 1
17. Interior/ Ceiling plan 2
18. Interior/ Lightning plan 1
19. Interior/ Lightning plan 2
20. Interior/ Outdoor Lightning plan
21. Interior/ Electrical plan 1
22. Interior/ Electrical plan 2
23. Interior/ Outdoor Electrical plan
24. Interior/ Power socket plan 1
25. Interior/ Power socket plan 2

/ C

26. Interior/ Kitchen
27. Interior/ Kitchen/ Furniture
28. Interior/ Living - dining spaces F1
29. Interior/ Common - praying spaces F2
30. Interior/ WC & furniture
31. Interior/ Bedroom & furniture
32. Exterior/ Outdoor spaces
33. Exterior/ Night view

/ D

34. Pattern/ Parametric design

/ E

35. Design process/ Experimentation & Iterations
36. Design process/ Methodology on information management

/ F

37. Remarks

○ Page mark

CONTENTS

Intro

1. Site assessment| Brief
2. References
3. Design Concept diagrams

Proposal

/ A

4. Architecture/ Floor plan 1
5. Architecture/ Floor plan 1/ dimension
6. Architecture/ Floor plan 2
7. Architecture/ Floor plan 2/ dimension
8. Architecture/ Roof plan
9. Architecture/ Roof plan/ dimension
10. Architecture/ Elevations
11. Architecture/ Sections
12. Architecture/ Door details
13. Architecture/ 3D visualizations

/ B

14. Interior/ Floor (tiled) plan 1
15. Interior/ Floor (tiled) plan 2
16. Interior/ Ceiling plan 1
17. Interior/ Ceiling plan 2
18. Interior/ Lightning plan 1
19. Interior/ Lightning plan 2
20. Interior/ Outdoor Lightning plan
21. Interior/ Electrical plan 1
22. Interior/ Electrical plan 2
23. Interior/ Outdoor Electrical plan
24. Interior/ Power socket plan 1
25. Interior/ Power socket plan 2

/ C

26. Interior/ Kitchen
27. Interior/ Kitchen/ Furniture
28. Interior/ Living - dining spaces F1
29. Interior/ Common - praying spaces F2
30. Interior/ WC & furniture
31. Interior/ Bedroom & furniture
32. Exterior/ Outdoor spaces
33. Exterior/ Night view

/ D

34. Pattern/ Parametric design

/ E

35. Design process/ Experimentation & Iterations
36. Design process/ Methodology on information management

/ F

37. Remarks

○ Page mark

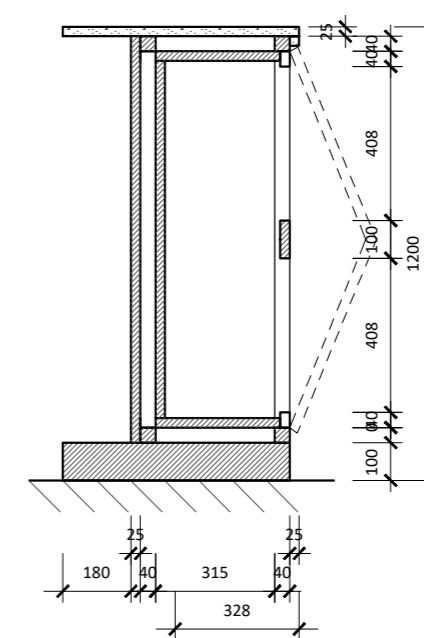
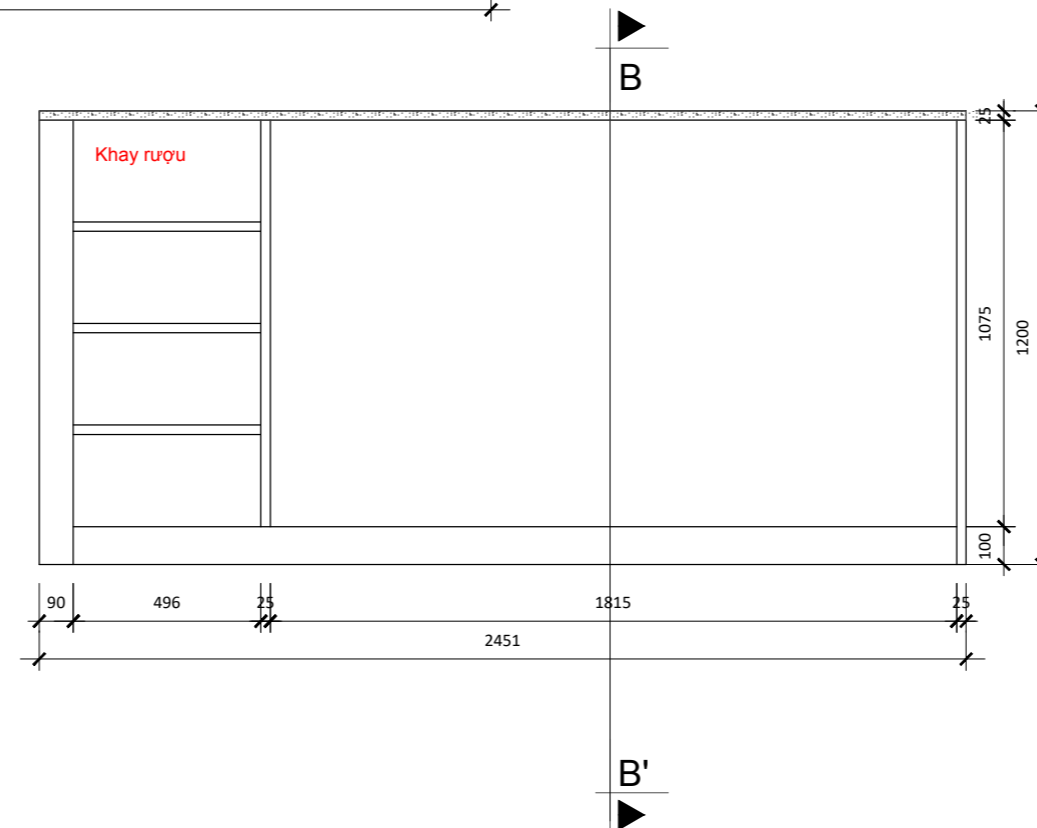
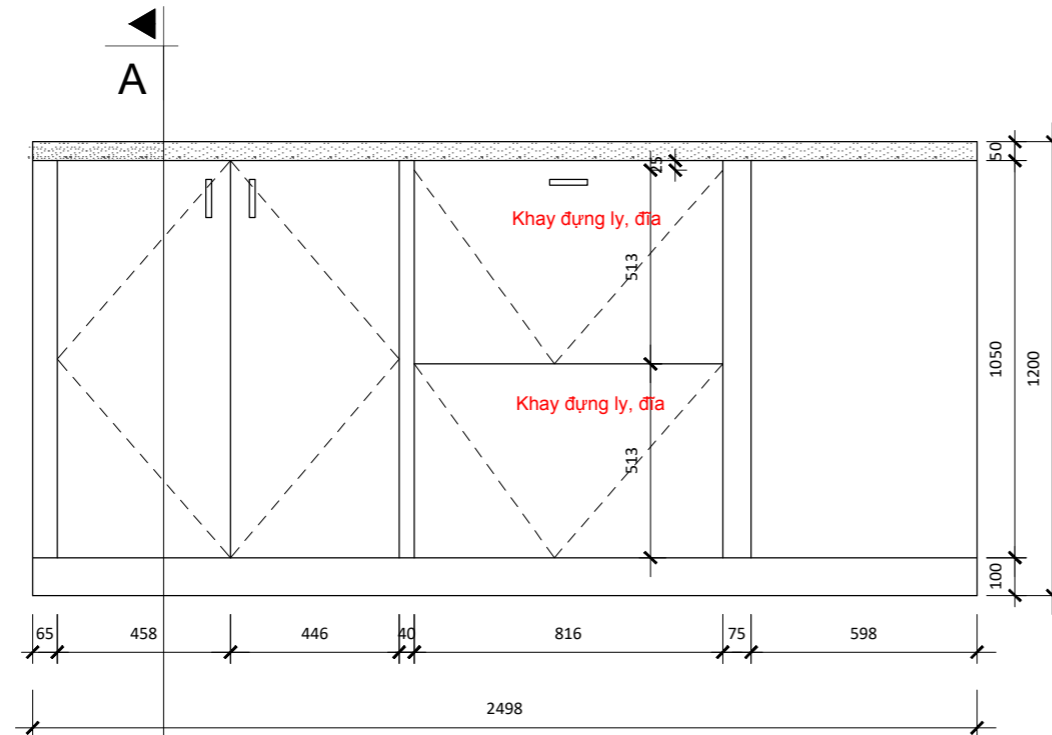
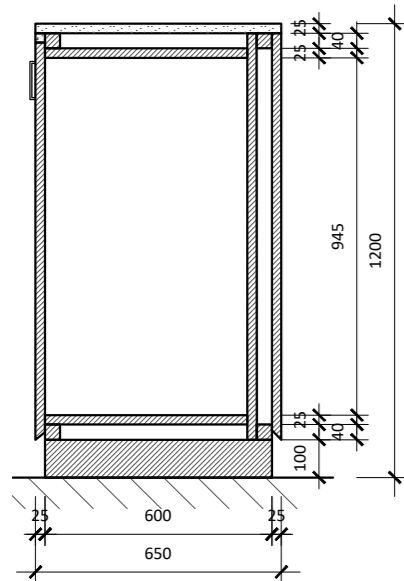
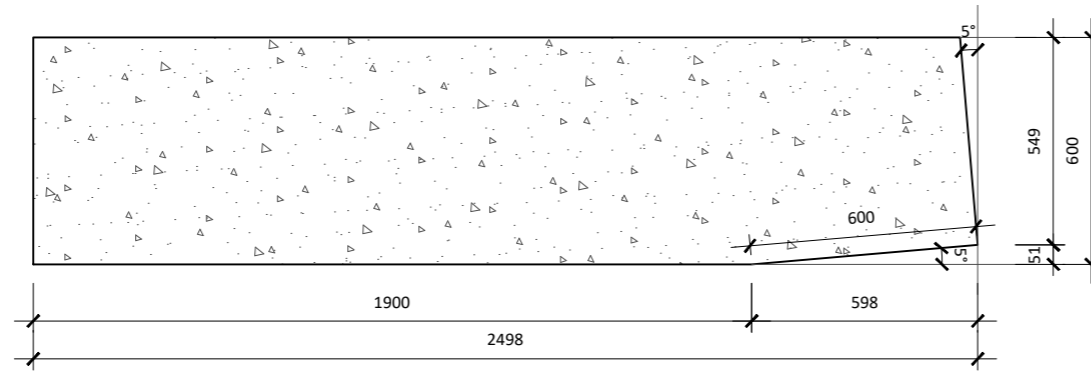



CONTENTS

Intro

1. Site assessment| Brief
2. References
3. Design Concept diagrams

Proposal

/ A

4. Architecture/ Floor plan 1
5. Architecture/ Floor plan 1/ dimension
6. Architecture/ Floor plan 2
7. Architecture/ Floor plan 2/ dimension
8. Architecture/ Roof plan
9. Architecture/ Roof plan/ dimension
10. Architecture/ Elevations
11. Architecture/ Sections
12. Architecture/ Door details
13. Architecture/ 3D visualizations

/ B

14. Interior/ Floor (tiled) plan 1
15. Interior/ Floor (tiled) plan 2
16. Interior/ Ceiling plan 1
17. Interior/ Ceiling plan 2
18. Interior/ Lightning plan 1
19. Interior/ Lightning plan 2
20. Interior/ Outdoor Lightning plan
21. Interior/ Electrical plan 1
22. Interior/ Electrical plan 2
23. Interior/ Outdoor Electrical plan
24. Interior/ Power socket plan 1
25. Interior/ Power socket plan 2

/ C

26. Interior/ Kitchen
27. Interior/ Kitchen/ Furniture
28. Interior/ Living - dining spaces F1
29. Interior/ Common - praying spaces F2
30. Interior/ WC & furniture
31. Interior/ Bedroom & furniture
32. Exterior/ Outdoor spaces
33. Exterior/ Night view

/ D

34. Pattern/ Parametric design

/ E

35. Design process/ Experimentation & Iterations
36. Design process/ Methodology on information management

/ F

37. Remarks

28 Page mark

3D VISUALIZATION
LIVING SPACE

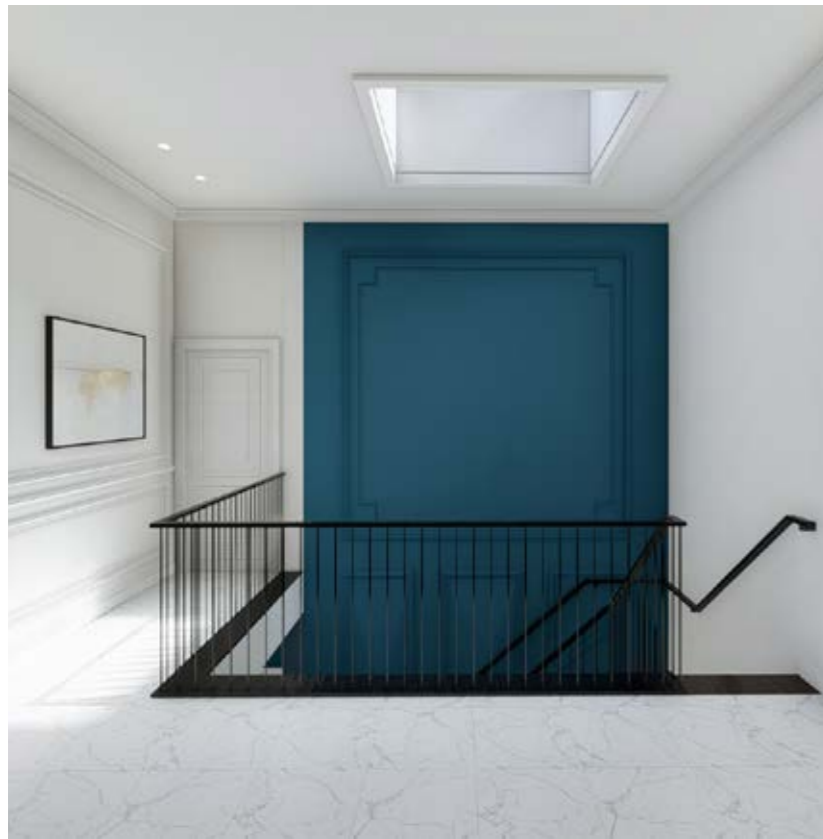

3D VISUALIZATION
COMMON SPACE FLOOR 2



3D VISUALIZATION
SHRINING SPACE INTERSECTED BETWEEN BEDROOM AND BALCONY

CONTENTS

Intro

1. Site assessment| Brief
2. References
3. Design Concept diagrams

Proposal

/ A

4. Architecture/ Floor plan 1
5. Architecture/ Floor plan 1/ dimension
6. Architecture/ Floor plan 2
7. Architecture/ Floor plan 2/ dimension
8. Architecture/ Roof plan
9. Architecture/ Roof plan/ dimension
10. Architecture/ Elevations
11. Architecture/ Sections
12. Architecture/ Door details
13. Architecture/ 3D visualizations

/ B

14. Interior/ Floor (tiled) plan 1
15. Interior/ Floor (tiled) plan 2
16. Interior/ Ceiling plan 1
17. Interior/ Ceiling plan 2
18. Interior/ Lightning plan 1
19. Interior/ Lightning plan 2
20. Interior/ Outdoor Lightning plan
21. Interior/ Electrical plan 1
22. Interior/ Electrical plan 2
23. Interior/ Outdoor Electrical plan
24. Interior/ Power socket plan 1
25. Interior/ Power socket plan 2

/ C

26. Interior/ Kitchen
27. Interior/ Kitchen/ Furniture
28. Interior/ Living - dining spaces F1
29. Interior/ Common - praying spaces F2
30. Interior/ WC & furniture
31. Interior/ Bedroom & furniture
32. Exterior/ Outdoor spaces
33. Exterior/ Night view

/ D

34. Pattern/ Parametric design

/ E

35. Design process/ Experimentation & Iterations
36. Design process/ Methodology on information management

/ F

37. Remarks

29 Page mark

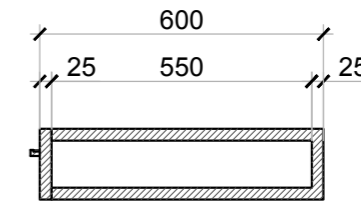
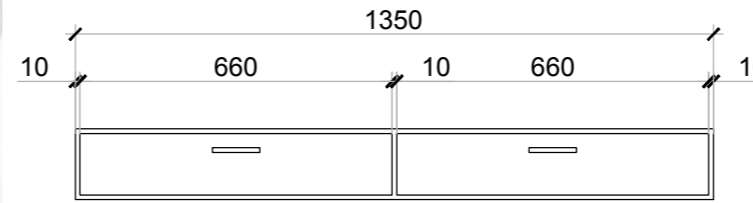

FLOOR 1
WC CANIBET

CONTENTS

Intro

1. Site assessment | Brief
2. References
3. Design Concept diagrams

Proposal

/ A

4. Architecture/ Floor plan 1
5. Architecture/ Floor plan 1/ dimension
6. Architecture/ Floor plan 2
7. Architecture/ Floor plan 2/ dimension
8. Architecture/ Roof plan
9. Architecture/ Roof plan/ dimension
10. Architecture/ Elevations
11. Architecture/ Sections
12. Architecture/ Door details
13. Architecture/ 3D visualizations

/ B

14. Interior/ Floor (tiled) plan 1
15. Interior/ Floor (tiled) plan 2
16. Interior/ Ceiling plan 1
17. Interior/ Ceiling plan 2
18. Interior/ Lightning plan 1
19. Interior/ Lightning plan 2
20. Interior/ Outdoor Lightning plan
21. Interior/ Electrical plan 1
22. Interior/ Electrical plan 2
23. Interior/ Outdoor Electrical plan
24. Interior/ Power socket plan 1
25. Interior/ Power socket plan 2

/ C

26. Interior/ Kitchen
27. Interior/ Kitchen/ Furniture
28. Interior/ Living - dining spaces F1
29. Interior/ Common - praying spaces F2
30. Interior/ WC & furniture
31. Interior/ Bedroom & furniture
32. Exterior/ Outdoor spaces
33. Exterior/ Night view

/ D

34. Pattern/ Parametric design

/ E

35. Design process/ Experimentation & Iterations
36. Design process/ Methodology on information management

/ F

37. Remarks

Page mark

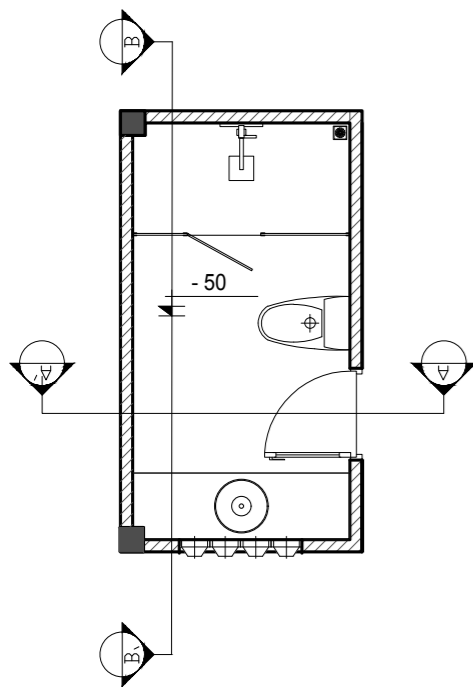

FLOOR 1
WC

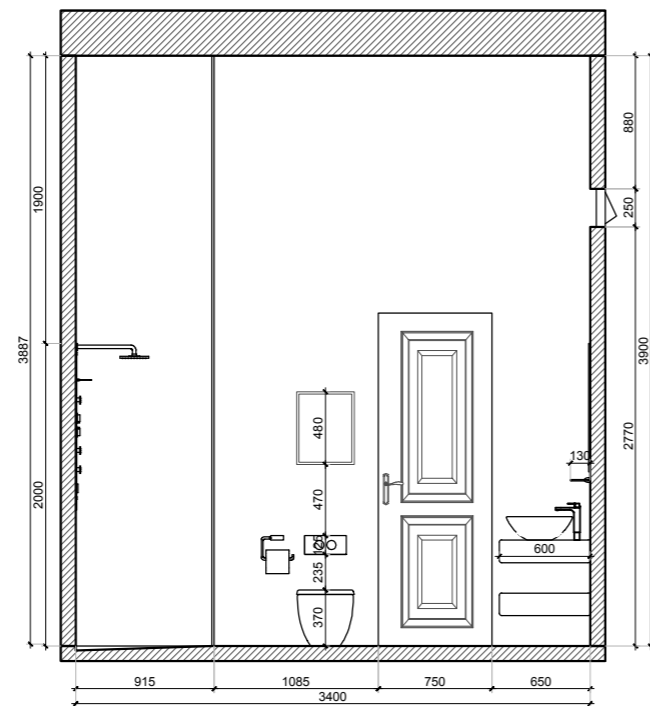

FLOOR 1
ELEVATION A-A'

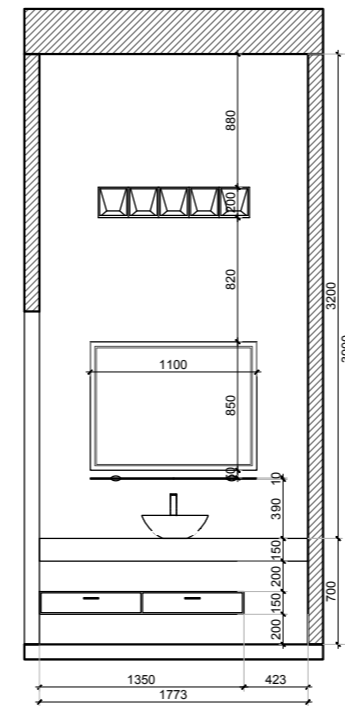

FLOOR 1
ELEVATION B-B'

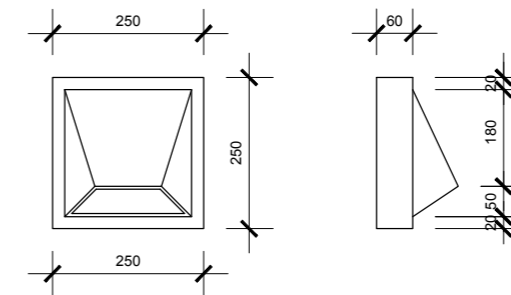

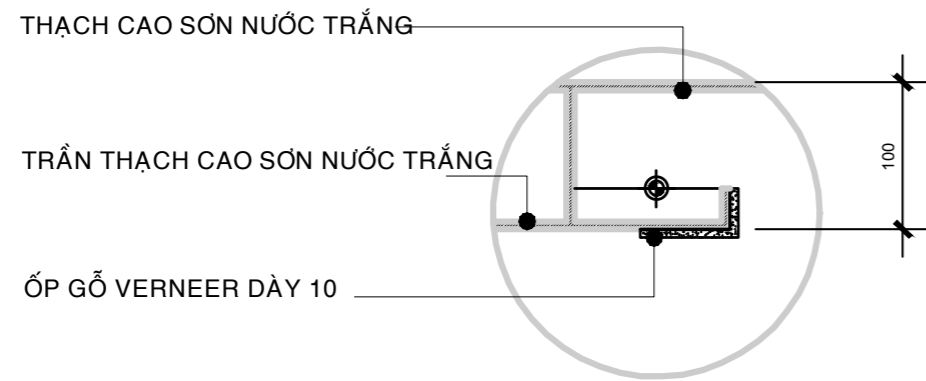

DETAIL
FALL CEILING

3D VISUALIZATION
MASTER BEDROOM

CONTENTS

Intro

1. Site assessment | Brief
2. References
3. Design Concept diagrams

Proposal

/ A

4. Architecture/ Floor plan 1
5. Architecture/ Floor plan 1/ dimension
6. Architecture/ Floor plan 2
7. Architecture/ Floor plan 2/ dimension
8. Architecture/ Roof plan
9. Architecture/ Roof plan/ dimension
10. Architecture/ Elevations
11. Architecture/ Sections
12. Architecture/ Door details
13. Architecture/ 3D visualizations

/ B

14. Interior/ Floor (tiled) plan 1
15. Interior/ Floor (tiled) plan 2
16. Interior/ Ceiling plan 1
17. Interior/ Ceiling plan 2
18. Interior/ Lightning plan 1
19. Interior/ Lightning plan 2
20. Interior/ Outdoor Lightning plan
21. Interior/ Electrical plan 1
22. Interior/ Electrical plan 2
23. Interior/ Outdoor Electrical plan
24. Interior/ Power socket plan 1
25. Interior/ Power socket plan 2

/ C

26. Interior/ Kitchen
27. Interior/ Kitchen/ Furniture
28. Interior/ Living - dining spaces F1
29. Interior/ Common - praying spaces F2
30. Interior/ WC & furniture
31. Interior/ Bedroom & furniture
32. Exterior/ Outdoor spaces
33. Exterior/ Night view

/ D

34. Pattern/ Parametric design

/ E

35. Design process/ Experimentation & Iterations
36. Design process/ Methodology on information management

/ F

37. Remarks

31 Page mark

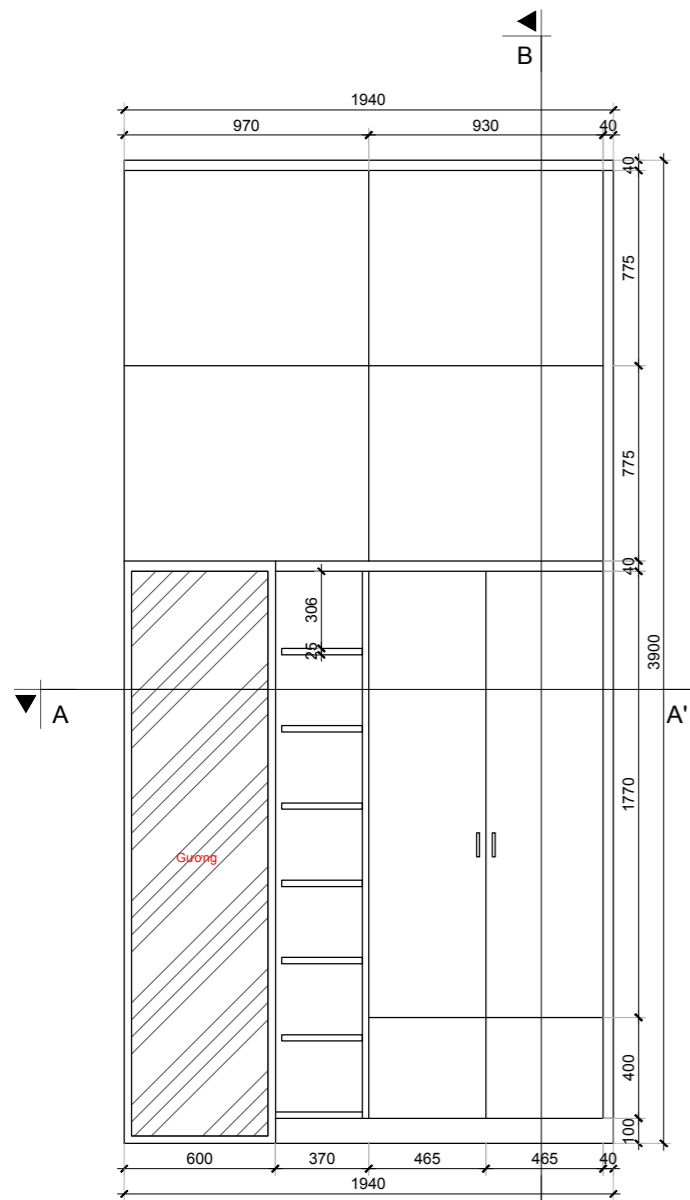

WARDROBE SCALE 1/30
ELEVATION

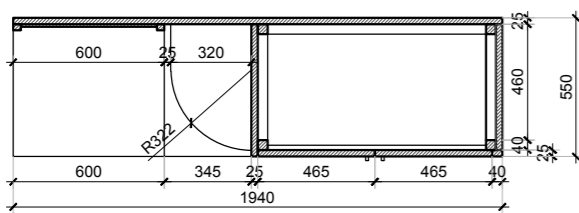

SCALE 1/30
SECTION AA'

DETAIL
FURNITURE BEDROOM CANIBET

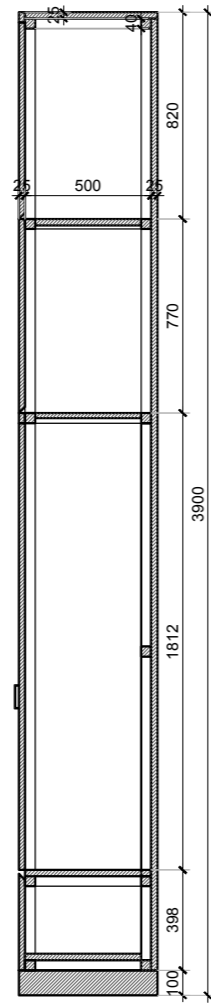

SCALE 1/30
SECTION BB'



ELEVATION



PERSPECTIVE

CONTENTS

Intro

1. Site assessment | Brief
2. References
3. Design Concept diagrams

Proposal

/ A

4. Architecture/ Floor plan 1
5. Architecture/ Floor plan 1/ dimension
6. Architecture/ Floor plan 2
7. Architecture/ Floor plan 2/ dimension
8. Architecture/ Roof plan
9. Architecture/ Roof plan/ dimension
10. Architecture/ Elevations
11. Architecture/ Sections
12. Architecture/ Door details
13. Architecture/ 3D visualizations

/ B

14. Interior/ Floor (tiled) plan 1
15. Interior/ Floor (tiled) plan 2
16. Interior/ Ceiling plan 1
17. Interior/ Ceiling plan 2
18. Interior/ Lightning plan 1
19. Interior/ Lightning plan 2
20. Interior/ Outdoor Lightning plan
21. Interior/ Electrical plan 1
22. Interior/ Electrical plan 2
23. Interior/ Outdoor Electrical plan
24. Interior/ Power socket plan 1
25. Interior/ Power socket plan 2

/ C

26. Interior/ Kitchen
27. Interior/ Kitchen/ Furniture
28. Interior/ Living - dining spaces F1
29. Interior/ Common - praying spaces F2
30. Interior/ WC & furniture
31. Interior/ Bedroom & furniture
32. Exterior/ Outdoor spaces
33. Exterior/ Night view

/ D

34. Pattern/ Parametric design

/ E

35. Design process/ Experimentation & Iterations
36. Design process/ Methodology on information management

/ F

37. Remarks

Page mark



CONTENTS

Intro

1. Site assessment| Brief
2. References
3. Design Concept diagrams

Proposal

/ A

4. Architecture/ Floor plan 1
5. Architecture/ Floor plan 1/ dimension
6. Architecture/ Floor plan 2
7. Architecture/ Floor plan 2/ dimension
8. Architecture/ Roof plan
9. Architecture/ Roof plan/ dimension
10. Architecture/ Elevations
11. Architecture/ Sections
12. Architecture/ Door details
13. Architecture/ 3D visualizations

/ B

14. Interior/ Floor (tiled) plan 1
15. Interior/ Floor (tiled) plan 2
16. Interior/ Ceiling plan 1
17. Interior/ Ceiling plan 2
18. Interior/ Lightning plan 1
19. Interior/ Lightning plan 2
20. Interior/ Outdoor Lightning plan
21. Interior/ Electrical plan 1
22. Interior/ Electrical plan 2
23. Interior/ Outdoor Electrical plan
24. Interior/ Power socket plan 1
25. Interior/ Power socket plan 2

/ C

26. Interior/ Kitchen
27. Interior/ Kitchen/ Furniture
28. Interior/ Living - dining spaces F1
29. Interior/ Common - praying spaces F2
30. Interior/ WC & furniture
31. Interior/ Bedroom & furniture
32. Exterior/ Outdoor spaces
33. Exterior/ Night view

/ D

34. Pattern/ Parametric design

/ E

35. Design process/ Experimentation & Iterations
36. Design process/ Methodology on information management

/ F

37. Remarks

32 Page mark

3D VISUALIZATION

OUTDOOR SPACES FRONTYARD AND BACKYARD



'Inside out' effect at night - a deeper dimension proposed by the combination of contradict interior and exterior colors.



Outdoor lightning is install for semi-spaces: small garden and the leading path from balcony to the gate. This method helps to encourage outdoor time-spending in the evening.

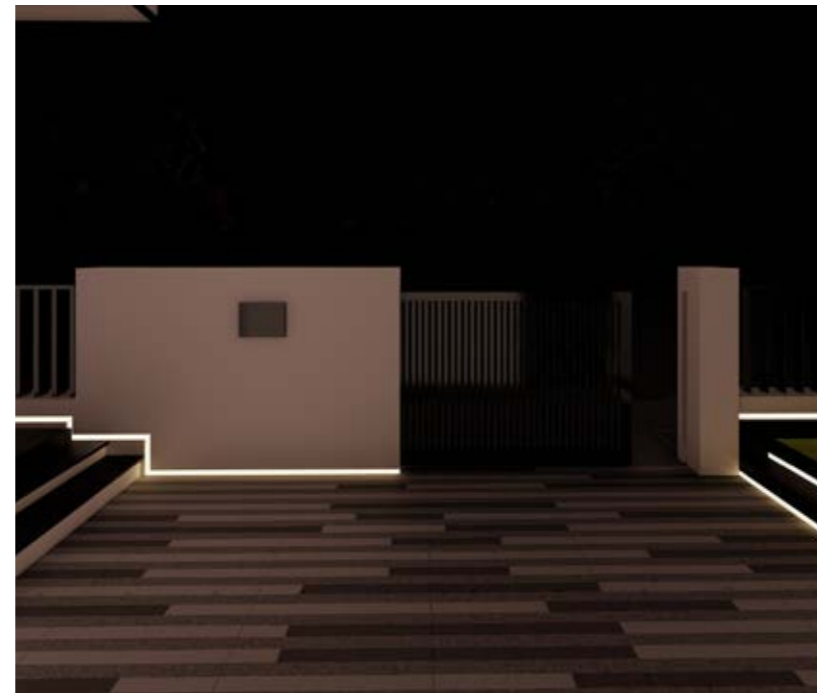
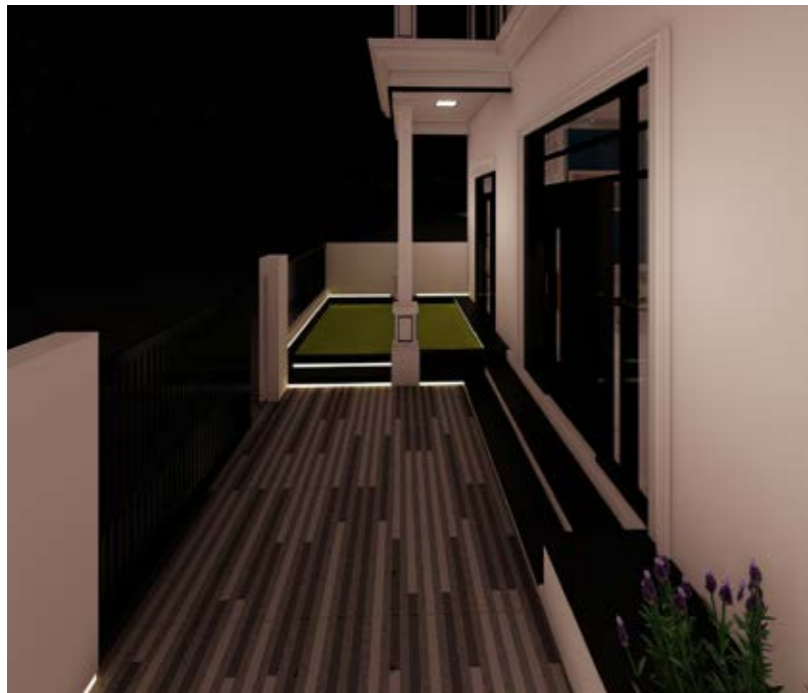

3D VISUALIZATION
AT NIGHT

CONTENTS

Intro

1. Site assessment| Brief
2. References
3. Design Concept diagrams

Proposal

/ A

4. Architecture/ Floor plan 1
5. Architecture/ Floor plan 1/ dimension
6. Architecture/ Floor plan 2
7. Architecture/ Floor plan 2/ dimension
8. Architecture/ Roof plan
9. Architecture/ Roof plan/ dimension
10. Architecture/ Elevations
11. Architecture/ Sections
12. Architecture/ Door details
13. Architecture/ 3D visualizations

/ B

14. Interior/ Floor (tiled) plan 1
15. Interior/ Floor (tiled) plan 2
16. Interior/ Ceiling plan 1
17. Interior/ Ceiling plan 2
18. Interior/ Lightning plan 1
19. Interior/ Lightning plan 2
20. Interior/ Outdoor Lightning plan
21. Interior/ Electrical plan 1
22. Interior/ Electrical plan 2
23. Interior/ Outdoor Electrical plan
24. Interior/ Power socket plan 1
25. Interior/ Power socket plan 2

/ C

26. Interior/ Kitchen
27. Interior/ Kitchen/ Furniture
28. Interior/ Living - dining spaces F1
29. Interior/ Common - praying spaces F2
30. Interior/ WC & furniture
31. Interior/ Bedroom & furniture
32. Exterior/ Outdoor spaces
33. Exterior/ Night view

/ D

34. Pattern/ Parametric design

/ E

35. Design process/ Experimentation & Iterations
36. Design process/ Methodology on information management

/ F

37. Remarks

 Page mark



3D VISUALIZATION
PATTERN DESIGN FOR LIGHTING EFFECT



3D VISUALIZATION
PATTERN DESIGN FOR LIGHTING EFFECT

CONTENTS

Intro

1. Site assessment | Brief
2. References
3. Design Concept diagrams

Proposal

/ A

4. Architecture/ Floor plan 1
5. Architecture/ Floor plan 1/ dimension
6. Architecture/ Floor plan 2
7. Architecture/ Floor plan 2/ dimension
8. Architecture/ Roof plan
9. Architecture/ Roof plan/ dimension
10. Architecture/ Elevations
11. Architecture/ Sections
12. Architecture/ Door details
13. Architecture/ 3D visualizations

/ B

14. Interior/ Floor (tiled) plan 1
15. Interior/ Floor (tiled) plan 2
16. Interior/ Ceiling plan 1
17. Interior/ Ceiling plan 2
18. Interior/ Lightning plan 1
19. Interior/ Lightning plan 2
20. Interior/ Outdoor Lightning plan
21. Interior/ Electrical plan 1
22. Interior/ Electrical plan 2
23. Interior/ Outdoor Electrical plan
24. Interior/ Power socket plan 1
25. Interior/ Power socket plan 2

/ C

26. Interior/ Kitchen
27. Interior/ Kitchen/ Furniture
28. Interior/ Living - dining spaces F1
29. Interior/ Common - praying spaces F2
30. Interior/ WC & furniture
31. Interior/ Bedroom & furniture
32. Exterior/ Outdoor spaces
33. Exterior/ Night view

/ D

34. Pattern/ Parametric design

/ E

35. Design process/ Experimentation & Iterations
36. Design process/ Methodology on information management

/ F

37. Remarks

34 Page mark



Exterior wall on balcony and window frame ideation

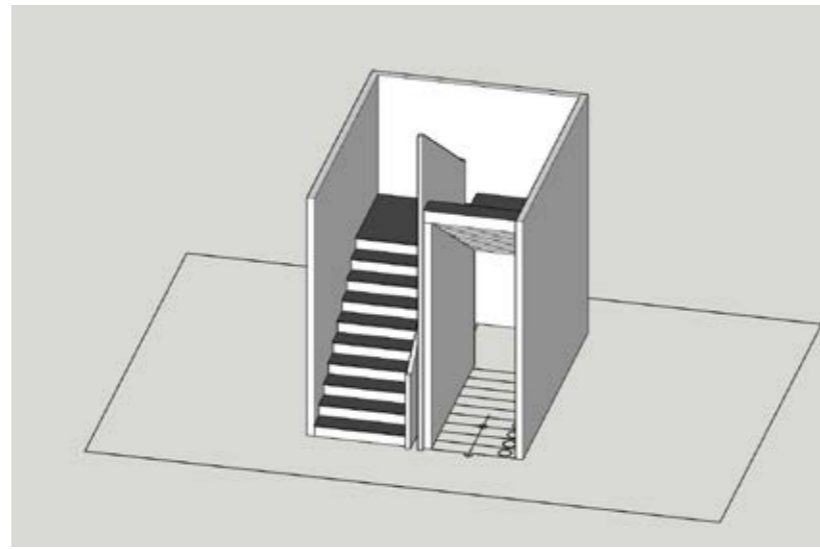

Initial staircase iteration

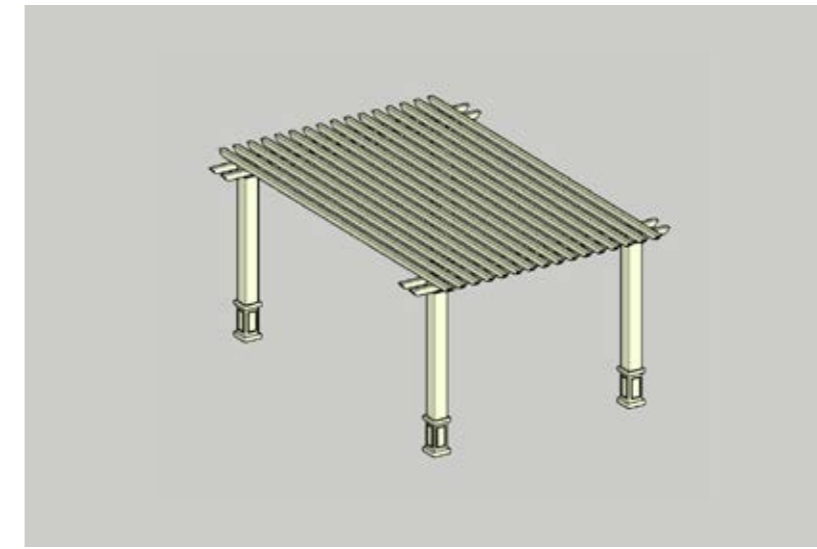

Pergola construction



Roof iterations

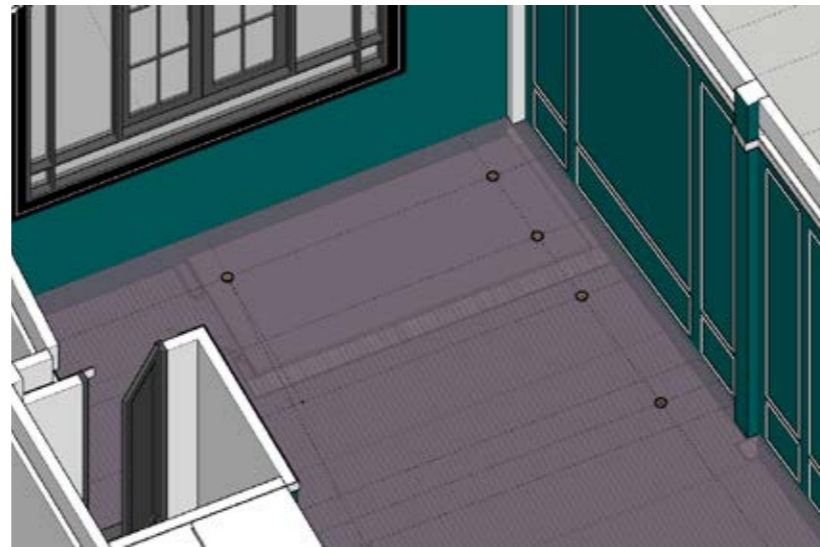

Allocating ceiling lights for rooms, spaces



Barbecue cabinet

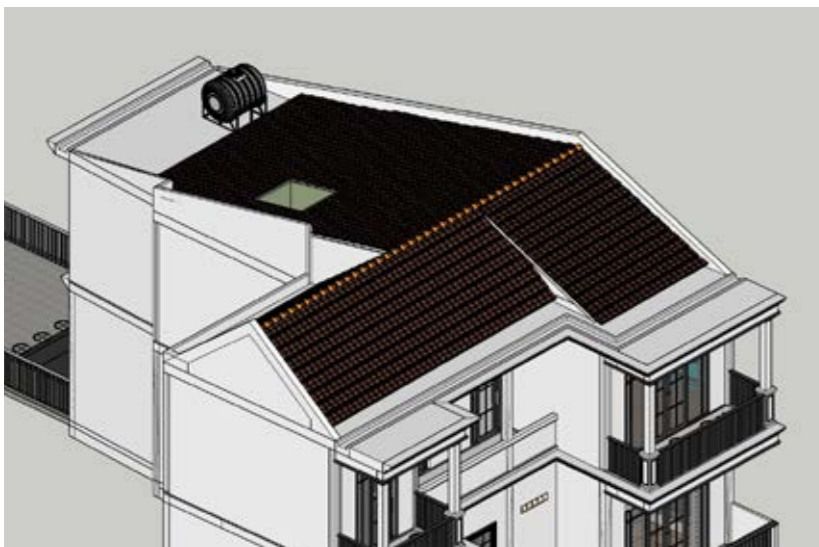

Roof iterations

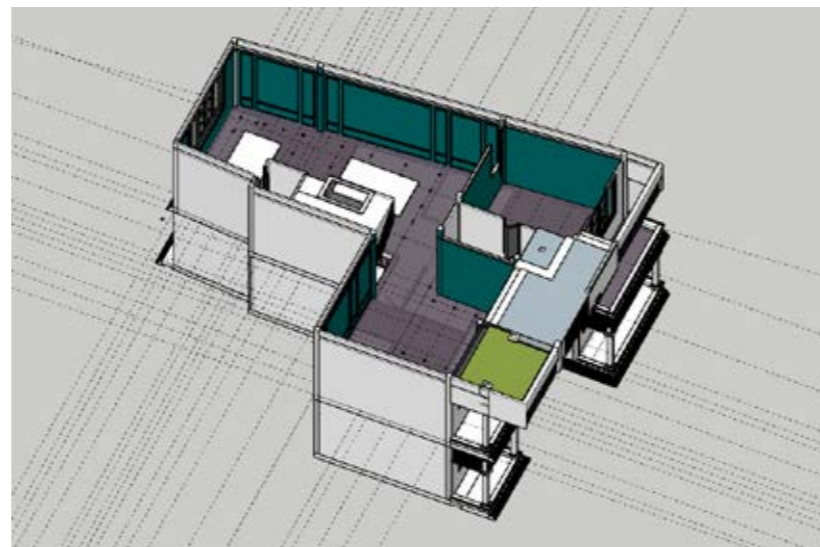

Allocating ceiling lights for rooms, spaces



Initial kitchen cabinet

CONTENTS

Intro

1. Site assessment | Brief
2. References
3. Design Concept diagrams

Proposal

/ A

4. Architecture/ Floor plan 1
5. Architecture/ Floor plan 1/ dimension
6. Architecture/ Floor plan 2
7. Architecture/ Floor plan 2/ dimension
8. Architecture/ Roof plan
9. Architecture/ Roof plan/ dimension
10. Architecture/ Elevations
11. Architecture/ Sections
12. Architecture/ Door details
13. Architecture/ 3D visualizations

/ B

14. Interior/ Floor (tiled) plan 1
15. Interior/ Floor (tiled) plan 2
16. Interior/ Ceiling plan 1
17. Interior/ Ceiling plan 2
18. Interior/ Lightning plan 1
19. Interior/ Lightning plan 2
20. Interior/ Outdoor Lightning plan
21. Interior/ Electrical plan 1
22. Interior/ Electrical plan 2
23. Interior/ Outdoor Electrical plan
24. Interior/ Power socket plan 1
25. Interior/ Power socket plan 2

/ C

26. Interior/ Kitchen
27. Interior/ Kitchen/ Furniture
28. Interior/ Living - dining spaces F1
29. Interior/ Common - praying spaces F2
30. Interior/ WC & furniture
31. Interior/ Bedroom & furniture
32. Exterior/ Outdoor spaces
33. Exterior/ Night view

/ D

34. Pattern/ Parametric design

/ E

35. Design process/ Experimentation & Iterations
36. Design process/ Methodology on information management

/ F

37. Remarks

○ Page mark

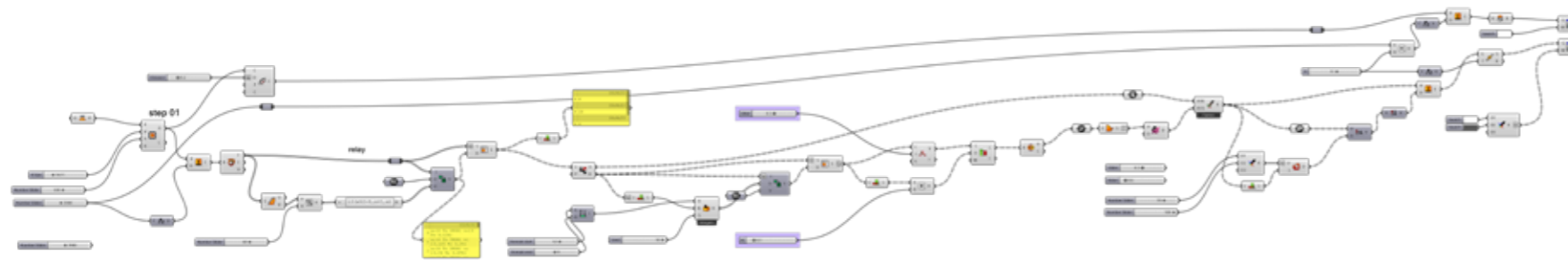

Rhino/ Grashopher for facade iterations



Installation's location

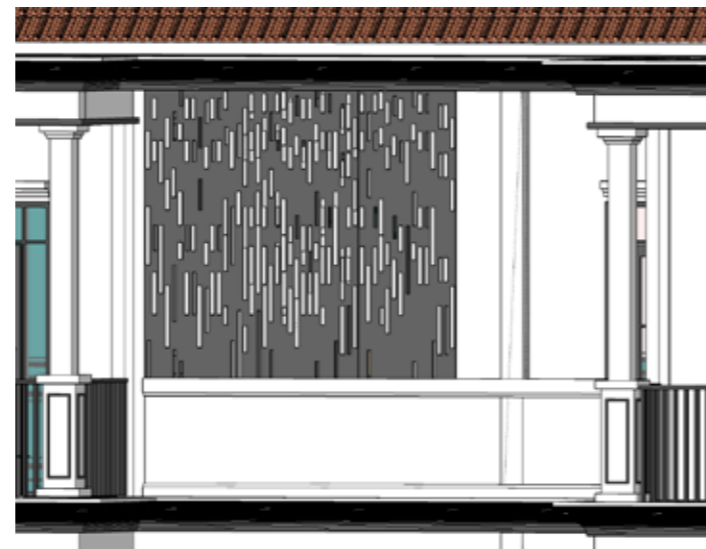

Iteration 1

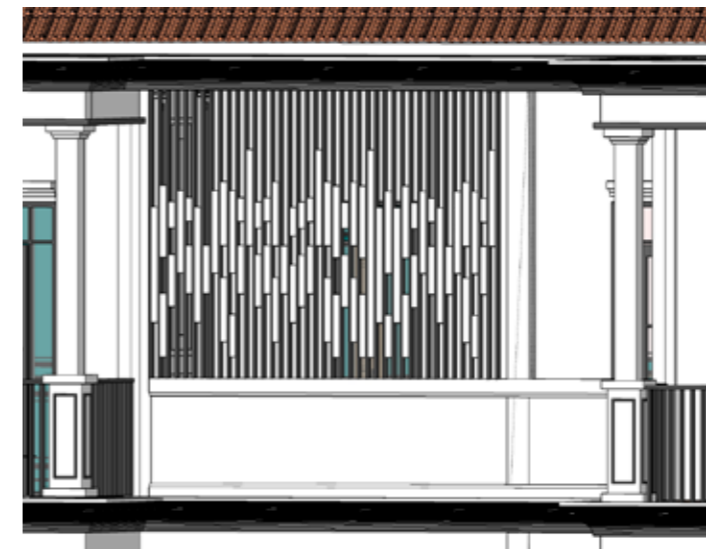

Iteration 2

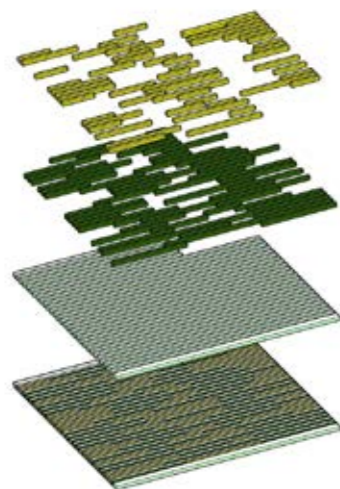

Other application: pavement design

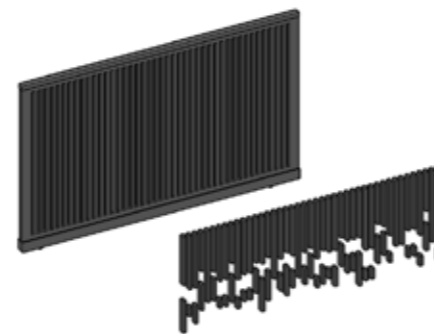

Other application: gate pattern

CONTENTS

Intro

1. Site assessment| Brief
2. References
3. Design Concept diagrams

Proposal

/ A

4. Architecture/ Floor plan 1
5. Architecture/ Floor plan 1/ dimension
6. Architecture/ Floor plan 2
7. Architecture/ Floor plan 2/ dimension
8. Architecture/ Roof plan
9. Architecture/ Roof plan/ dimension
10. Architecture/ Elevations
11. Architecture/ Sections
12. Architecture/ Door details
13. Architecture/ 3D visualizations

/ B

14. Interior/ Floor (tiled) plan 1
15. Interior/ Floor (tiled) plan 2
16. Interior/ Ceiling plan 1
17. Interior/ Ceiling plan 2
18. Interior/ Lightning plan 1
19. Interior/ Lightning plan 2
20. Interior/ Outdoor Lightning plan
21. Interior/ Electrical plan 1
22. Interior/ Electrical plan 2
23. Interior/ Outdoor Electrical plan
24. Interior/ Power socket plan 1
25. Interior/ Power socket plan 2

/ C

26. Interior/ Kitchen
27. Interior/ Kitchen/ Furniture
28. Interior/ Living - dining spaces F1
29. Interior/ Common - praying spaces F2
30. Interior/ WC & furniture
31. Interior/ Bedroom & furniture
32. Exterior/ Outdoor spaces
33. Exterior/ Night view

/ D

34. Pattern/ Parametric design

/ E

35. Design process/ Experimentation & Iterations
36. Design process/ Methodology on information management

/ F

37. Remarks

○ Page mark

Information management is necessary, especially during the process of design, there would be constant adjustments from different stakeholders, parts of projects. Complexity will arrive. Methods of information management helps to cope with potential confusions from individual and team. During this project, various medias were categorized and seperated into smaller topics & segments, upto >400 files (dwg, pdf, jpeg, lumion, skp...) linked through methods of file naming, xref & shortcut. Finally, submission files is compressed into a smaller amount files for sumission by cleaning up all previous segments.

Method 1: Folder preparation

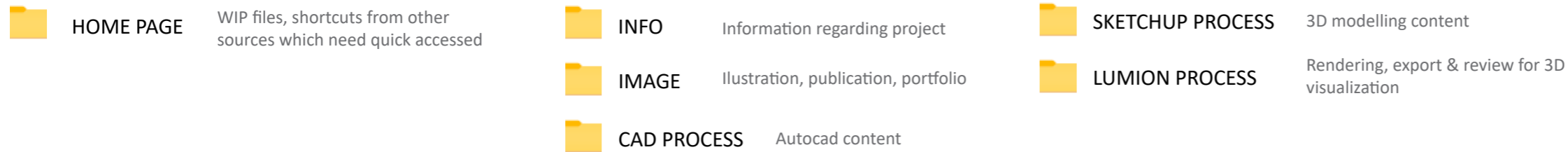

Method 2: Categorization

Autocad files are seperated for smaller segments following certain categories (of concept), to be easy for updating new contents. All segments are linked through XREF method in the software.

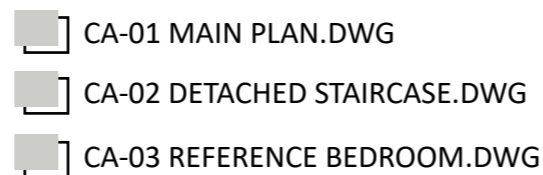

Method 3: File naming

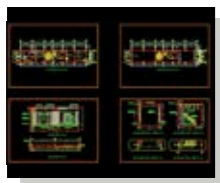

Each category is updated day-today process. New files will be added along the process. Naming file follows time-frame helps easily to manage new updates: yymmdd.

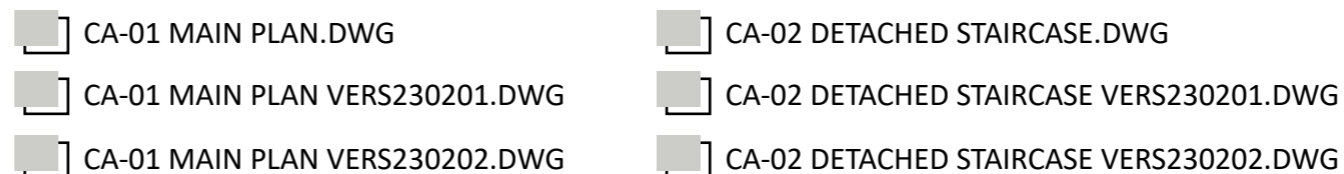

Method 4: Shortcuts

Shortcuts helps to minimize time for retrieving files from folders during the process. They can be deleted when the task is done.

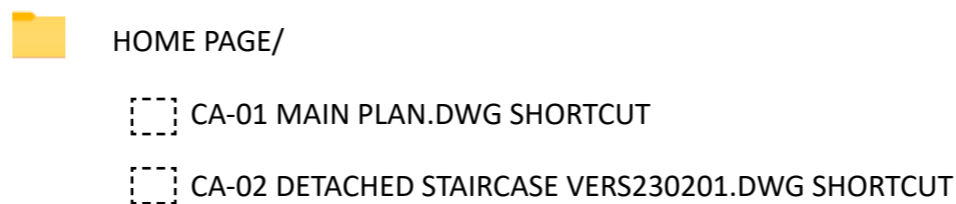

Method 5: Cleaning up

All segments can be cleaned up when the stage (of project) is finished. The submitted file is the first category with the latest date version.

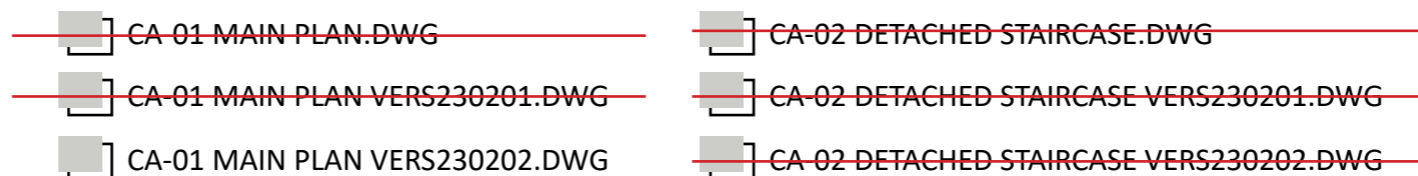

CONTENTS

Intro

1. Site assessment| Brief
2. References
3. Design Concept diagrams

Proposal

/ A

4. Architecture/ Floor plan 1
5. Architecture/ Floor plan 1/ dimension
6. Architecture/ Floor plan 2
7. Architecture/ Floor plan 2/ dimension
8. Architecture/ Roof plan
9. Architecture/ Roof plan/ dimension
10. Architecture/ Elevations
11. Architecture/ Sections
12. Architecture/ Door details
13. Architecture/ 3D visualizations

/ B

14. Interior/ Floor (tiled) plan 1
15. Interior/ Floor (tiled) plan 2
16. Interior/ Ceiling plan 1
17. Interior/ Ceiling plan 2
18. Interior/ Lightning plan 1
19. Interior/ Lightning plan 2
20. Interior/ Outdoor Lightning plan
21. Interior/ Electrical plan 1
22. Interior/ Electrical plan 2
23. Interior/ Outdoor Electrical plan
24. Interior/ Power socket plan 1
25. Interior/ Power socket plan 2

/ C

26. Interior/ Kitchen
27. Interior/ Kitchen/ Furniture
28. Interior/ Living - dining spaces F1
29. Interior/ Common - praying spaces F2
30. Interior/ WC & furniture
31. Interior/ Bedroom & furniture
32. Exterior/ Outdoor spaces
33. Exterior/ Night view

/ D

34. Pattern/ Parametric design

/ E

35. Design process/ Experimentation & Iterations
36. Design process/ Methodology on information management

/ F

37. Remarks

○ Page mark



REMARK 1/6

LIVING ROOM



REMARK 2/6

KITCHEN & BAR



REMARK 3/6
HALLWAY



REMARK 4/6
BEDROOM



REMARK 5/6

NATURAL SUNLIGHT EFFECT ON WALLS OF BALCONY & ROOM



REMARK 5/6
MINI GARDEN



REMARK 6/6

NIGHT BARBECUE

END.